

3209 Inductor

1. Ensure that power has been turned off and removed from all units.
2. Remove the Servo Power Module front cover.
3. Remove the fan assembly (A) for access, if necessary (3203).
4. Disconnect each lead from the terminals on the inductor (D), marking each with its location for replacement.
5. Remove the two screws (E) holding the inductor (D) to the rear panel and remove the inductor (D).
6. For replacement, reverse the above procedure.

3210 CR2 Relay

DANGER

THIS PROCEDURE REQUIRES THAT THE 230 VAC BE TURNED OFF AND DISCONNECTED AT THE POWER SOURCE PRIOR TO STARTING THE PROCEDURE. TURNING OFF THE SWITCH IS NOT SUFFICIENT.

1. Ensure that power has been turned off and removed from all units.
2. Remove the Servo Power Module front cover.
3. Disconnect each lead from the terminals on the relay (B), marking each with its location for replacement.
4. Remove the two screws (C) holding the relay (B) to the rear panel and remove the relay.
5. For replacement, reverse the above procedure.

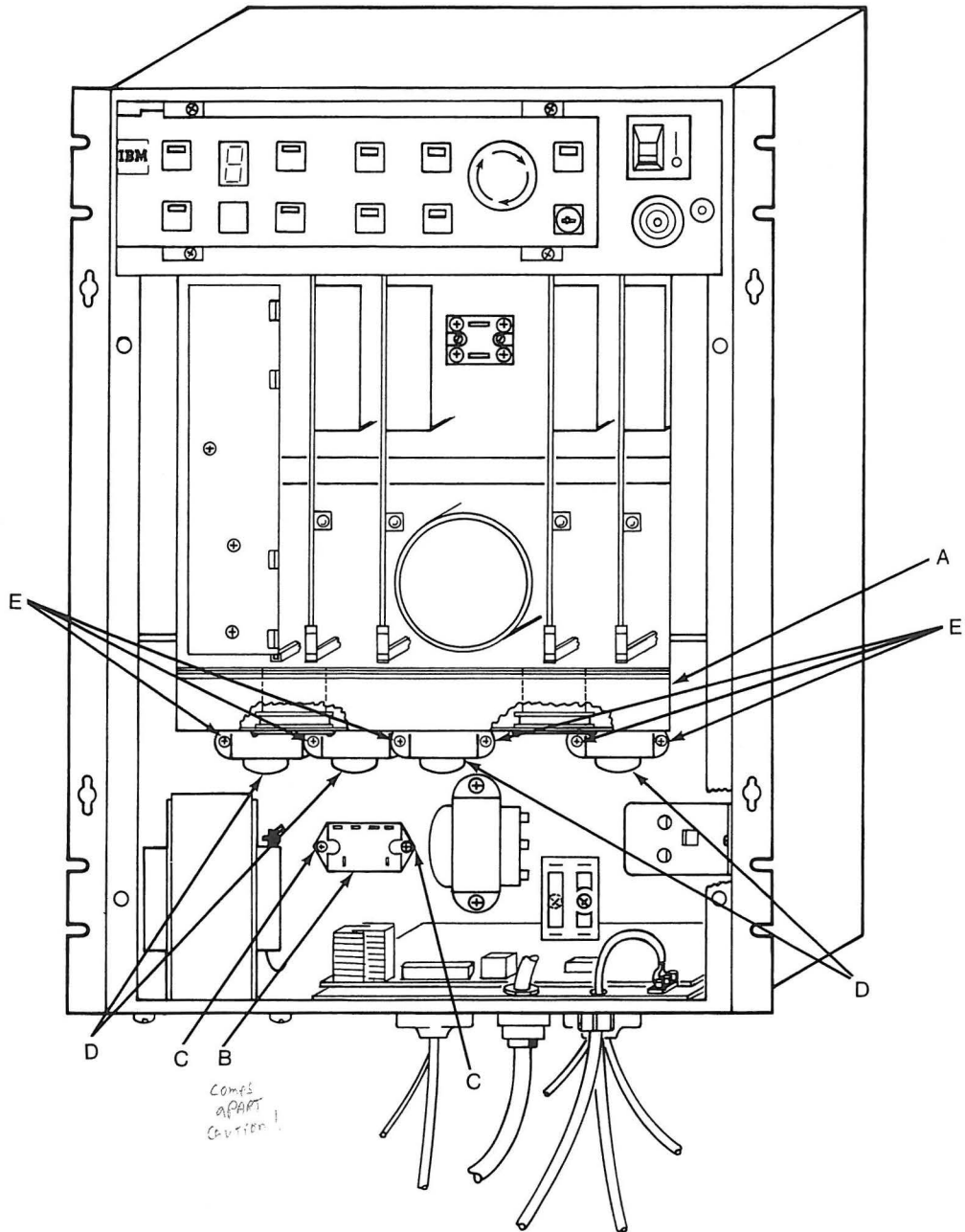

3211 Low Voltage Transformer

1. Ensure that power has been turned off and removed from all units.
2. Remove the Servo Power Module front cover.
3. Disconnect each lead from the terminals on the transformer (A), marking each with its location for replacement.
4. Remove the two screws (B) holding the transformer (A) to the rear panel and remove the transformer.
5. For replacement, reverse the above procedure.

3212 High Voltage Transformer

1. Ensure that power has been turned off and removed from all units.
2. Remove the Servo Power Module front cover.
3. Disconnect each lead from the terminals (D) on the power transformer (E), marking each with its location for replacement.
4. Remove the six screws (C) holding the power transformer (E) to the lower panel and remove the power transformer.
5. For replacement, reverse the above procedure.

3213 Operator Panel

1. Ensure that power has been turned off and removed from all units.
2. Remove the Servo Power Module front cover.
3. Remove the four front screws (F).
4. Pull the operator panel from the Servo Power Module and disconnect the cable from the rear of the box.
5. For replacement, reverse the above procedure.

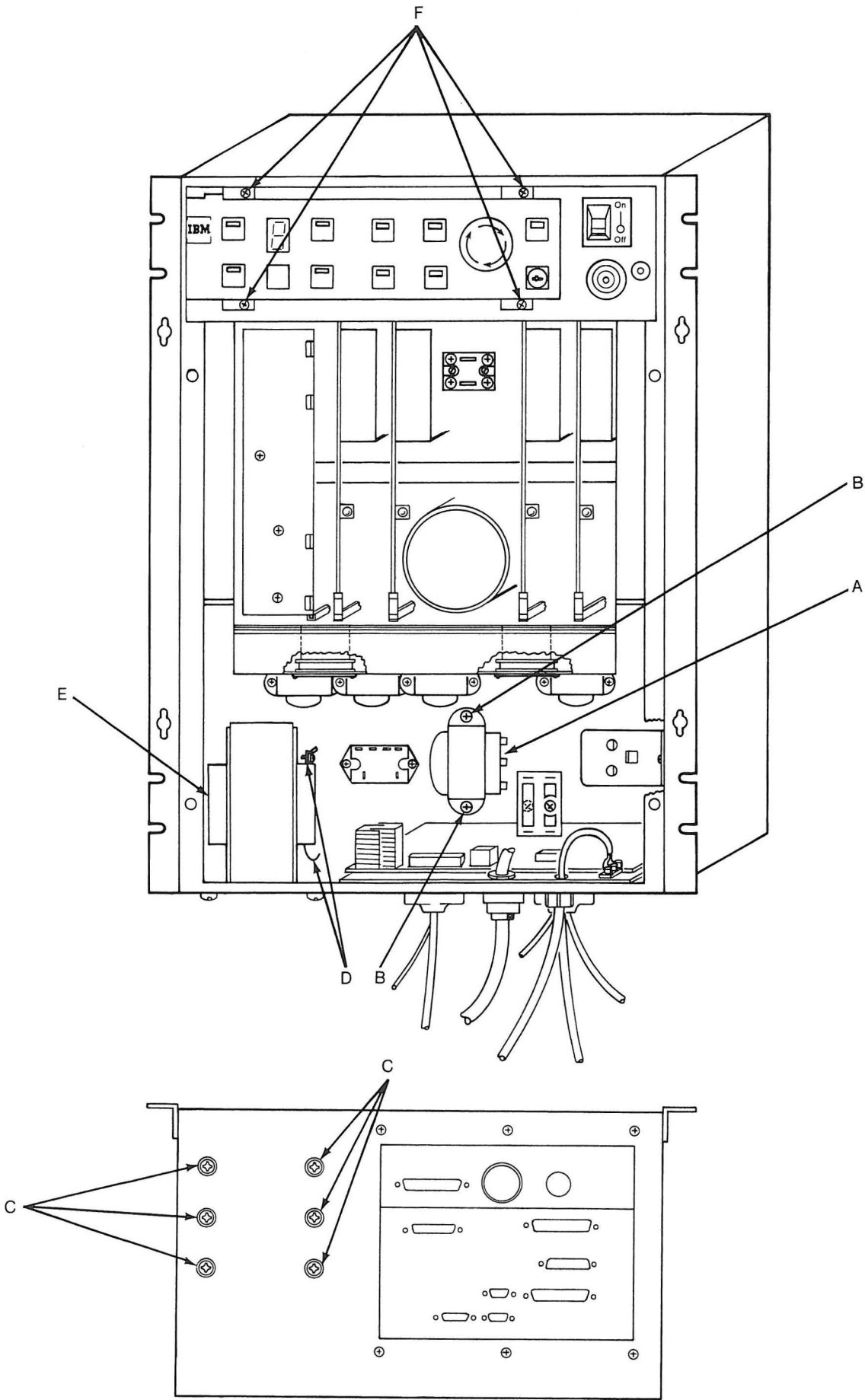

3214 Manip Stop Switch

1. Ensure that power has been turned off and removed from all units.
2. Remove the Servo Power Module front cover.
3. Remove the four front screws that hold the operator panel in the Servo Power Module.
4. Pull the operator panel forward and disconnect the cable from the rear of the box.
5. Remove the four screws (G) that hold the rear access plate (C).
6. Pull the plate back to remove J12 (A) from the switch card (D).
7. Remove the rear access plate and J12 cable together. Note that the red tracer wire goes to pin 1.
8. Remove and mark the two wires to the switch body.
9. Loosen fully the two screws on the Manip Stop switch (E).
10. From the front, rotate the mushroom plunger counter-clockwise to separate the plunger from the switch body. Save the plunger for use later.
11. For replacement, assemble in reverse order.

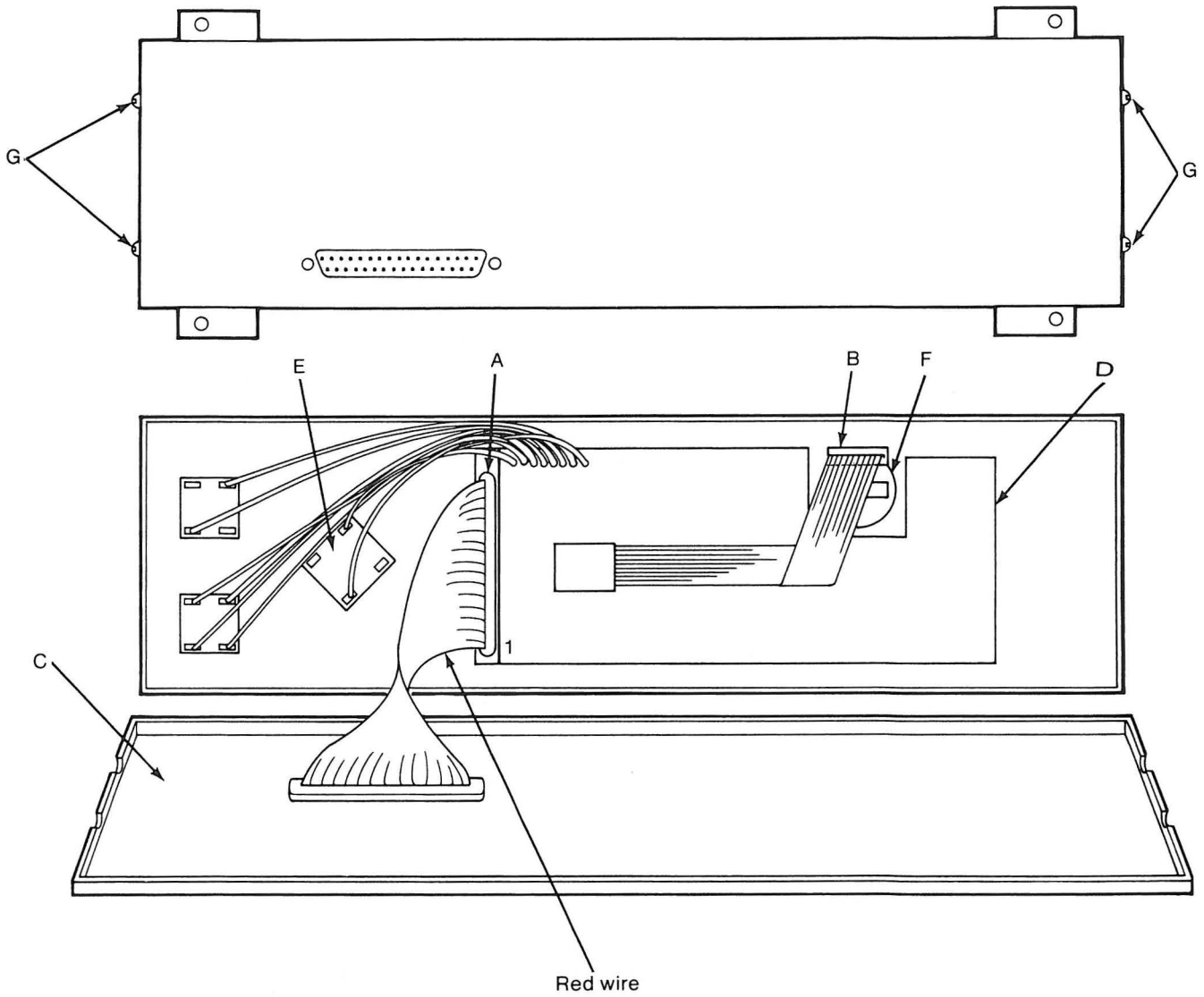

3215 LED Segment

1. Ensure that power has been turned off and removed from all units.
2. Remove the Servo Power Module front cover.
3. Remove the four screws that hold the operator panel in the Servo Power Module.
4. Pull the operator panel forward and disconnect the cable from the rear of the box.
5. Remove the four screws (G) to the rear access plate (C).
6. Pull the plate back to remove J12 (A) from the switch card (D).
7. Remove the rear access plate and J12 cable together. Note that the red tracer wire goes to pin 1.
8. Remove the J11 cable (B) at the LED segment (F).
9. Remove the plastic nut that holds the LED segment (F) to the front mask
10. From the front, remove the LED segment (F).
11. For replacement, assemble in reverse order.

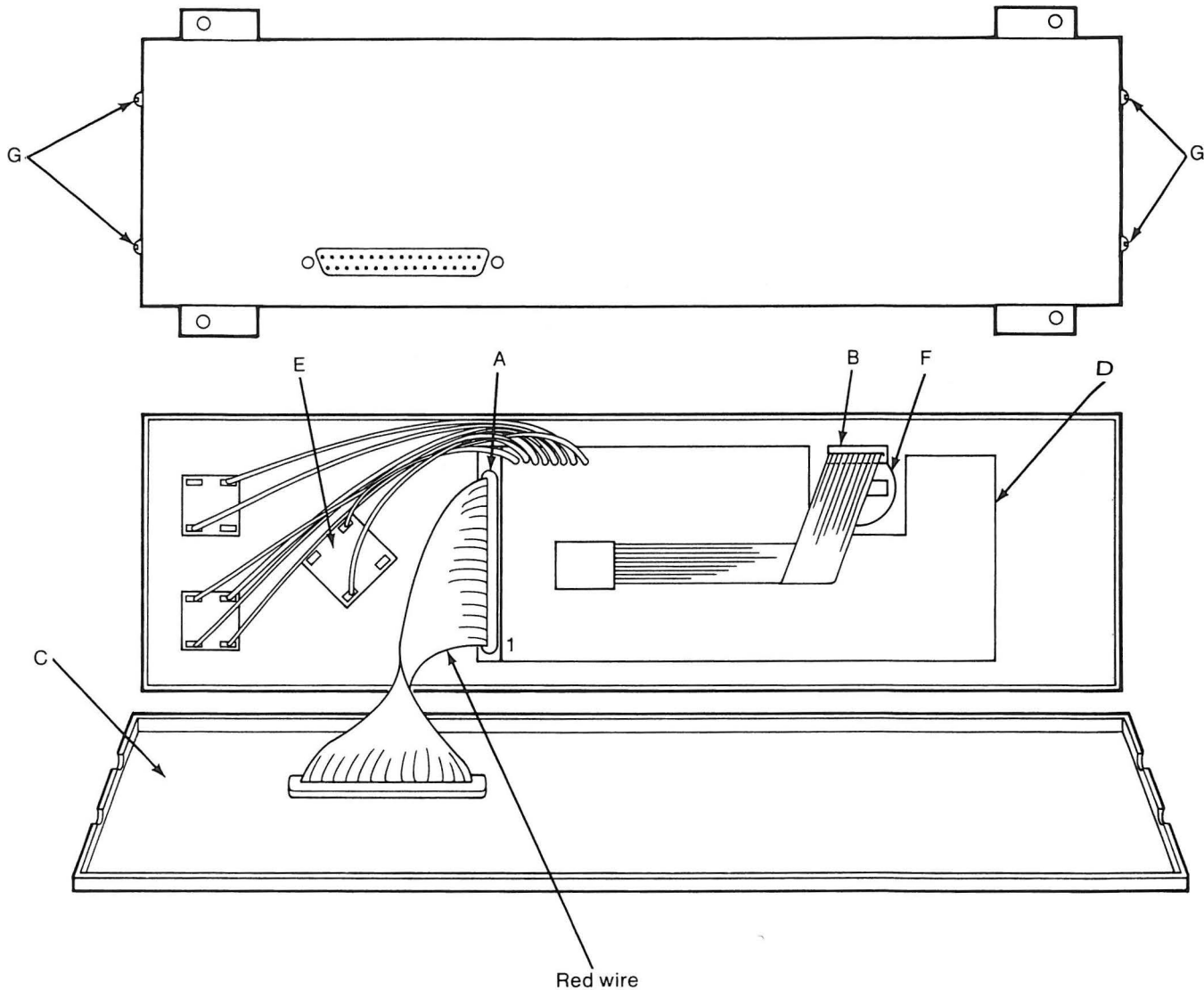

3216 Auto/Teach Key Switch

1. Ensure that power has been turned off and removed from all units.
2. Remove the Servo Power Module front cover.
3. Remove the four screws that hold the operator panel in the Servo Power Module.
4. Pull the operator panel forward and disconnect the cable from the rear of the box.
5. Remove the four screws (G) to the rear access plate (C), pull the plate back to remove J12 (A) from the switch card (D), remove the rear access plate and J12 cable together. Note that the red tracer wire goes to pin 1.
6. Unsolder and mark the four wires to the key switch body (J).
7. Firmly grasp the switch body, wiggle up and down slightly, and force the switch out the front of the panel.
8. For replacement, assemble in reverse order.

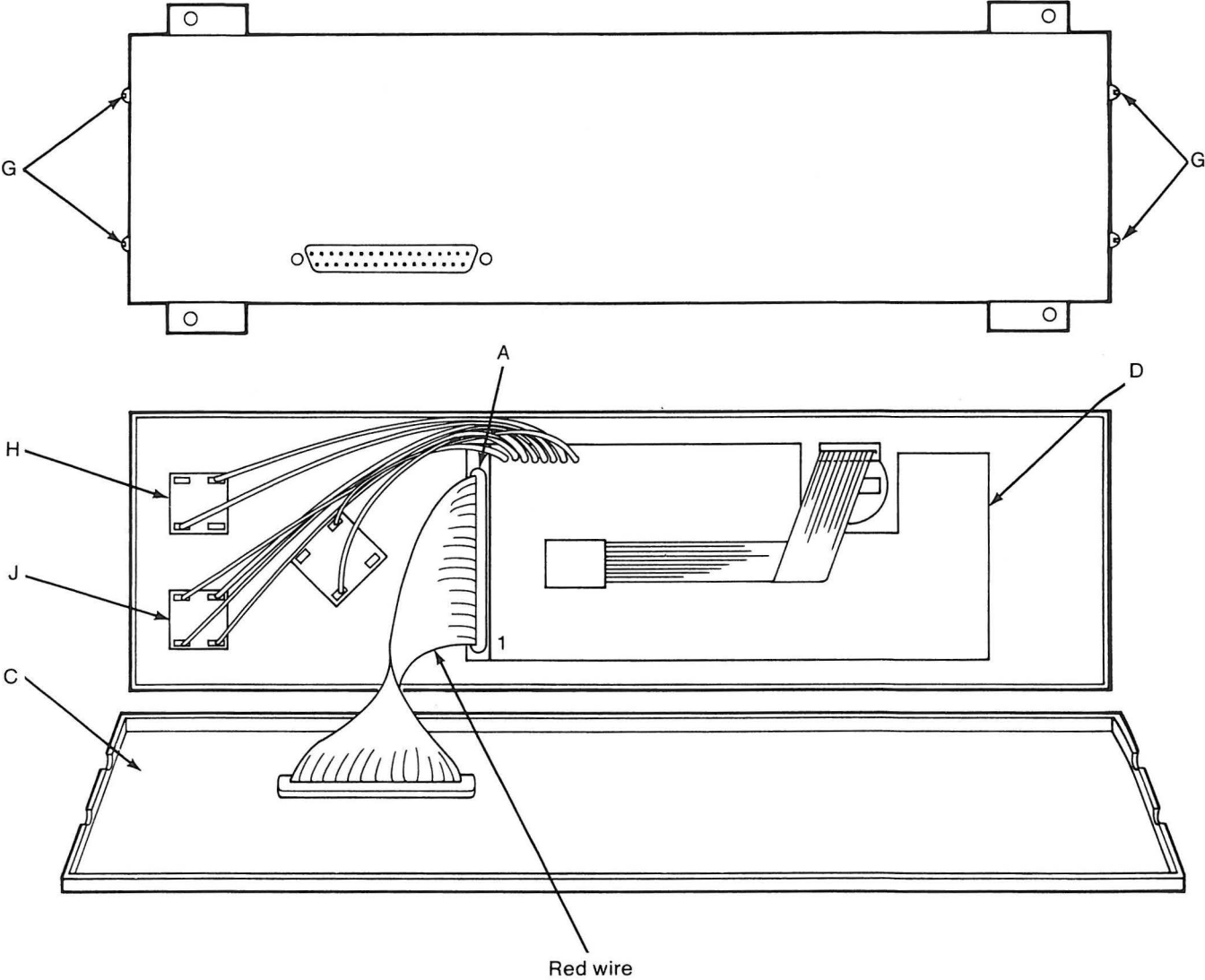

3217 Power (DC) LED Block

1. Ensure that power has been turned off and removed from all units.
2. Remove the Servo Power Module front cover.
3. Remove the four screws that hold the operator panel in the Servo Power Module.
4. Pull the operator panel forward and disconnect the cable from the rear of the box.
5. Remove the four screws (G) to the rear access plate (C).
6. Pull the plate back to remove J12 (A) from the switch card (D).
7. Remove the rear access plate and J12 cable together. Note that the red tracer wire goes to pin 1.
8. Remove and mark the two wires to the LED block (H).
9. Firmly grasp the LED block, wiggle up and down slightly, and force the block out the front of the panel.
10. For replacement, assemble in reverse order.

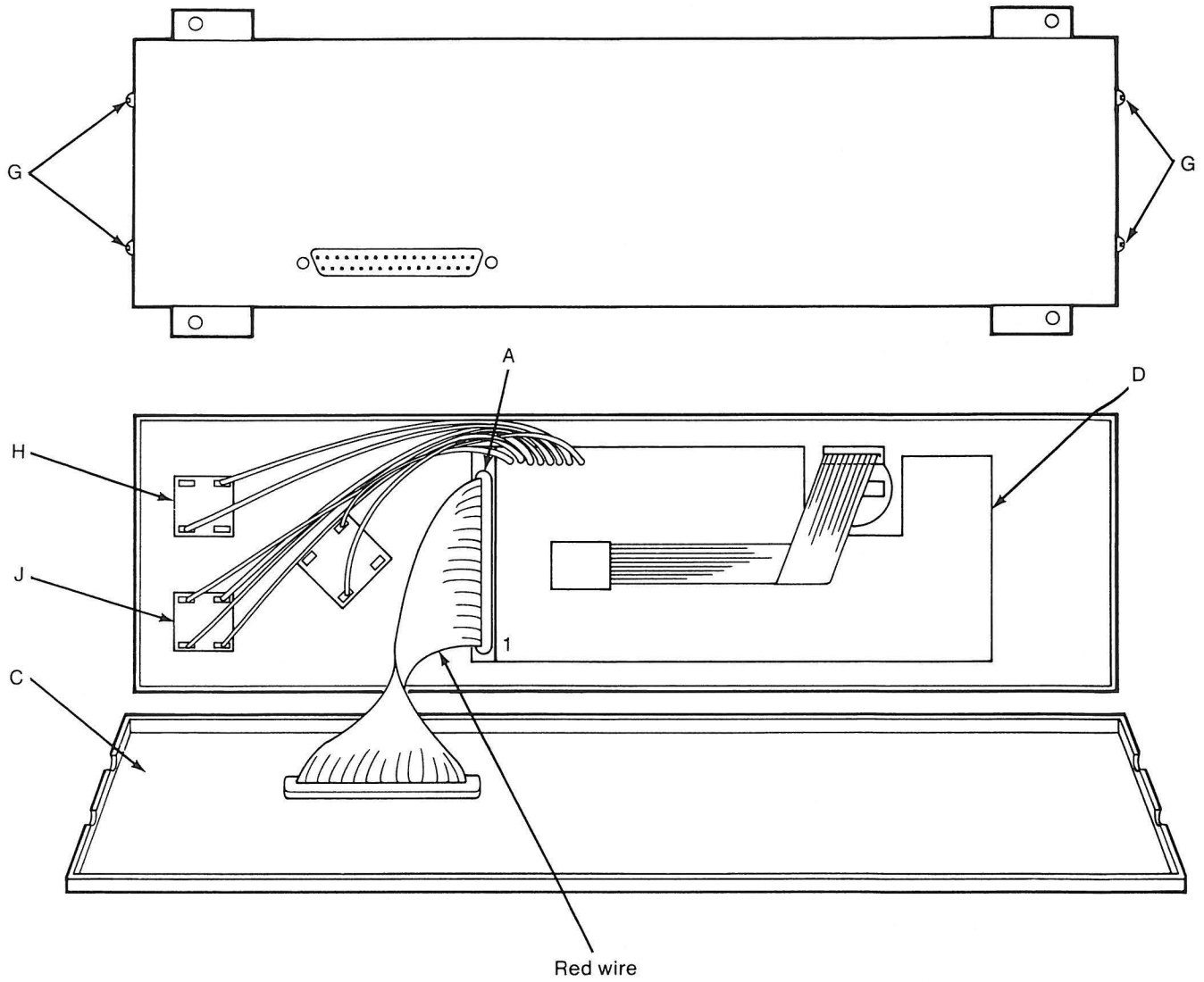

3218 Function Switch

1. Ensure that power has been turned off and removed from all units.
2. Remove the Servo Power Module front cover.
3. Remove the four screws that hold the operator panel in the Servo Power Module.
4. Pull the operator panel forward and disconnect the cable from the rear of the box.
5. Remove the four screws (G) to the rear access plate (C).
6. Pull the plate back to remove connector J12 (A) from the switch card (D).
7. Remove the rear access plate and cable J12 together. Note that the red tracer wire goes to pin 1.
8. Remove the cable J11 (B) from both the switch card connector and the LED block (F).
9. Use a desoldering tool to remove the solder from switch 1 and switch 3 connections on the switch card. (Flex the card slightly as you desolder to facilitate the removal of the switch card.)
10. Lift the switch card (D) out of the operator panel to allow access to the switches.
11. Remove the defective FRU by firmly grasping the body of the FRU. Wiggle the FRU up and down slightly, while forcing it out the front of the panel.
12. Discard the defective FRU.
13. Align the switch card (D) properly and place the switch card against the front of the panel from the inside of the box. (Ensure all switch and LED terminal holes on the switch card are fully open to facilitate installation of the switch card.)
14. Hold the switch card firmly in place and install all switches and the Error LED into the switch card.
15. Place the rear access plate (C), previously removed in step 4, against the face of the switches and the Error LED in the front of the operator panel. (Hold the switch card (D) level and try to place all switches and the Error LED in their respective locked positions at about the same time.)
16. Carefully press the switches and the Error LED with the rear access plate (C) until all switches and the Error LED seat firmly into place.

17. Place the operator panel face down and resolder the two connections at switch 1 and switch 3 of the switch card.
18. Reinstall the cable J11 (B) to the switch card and the LED block (F).
19. Reinstall connector J12 (A) to the switch card. The red tracer wire must be located at pin 1.
20. Reinstall the rear access plate (C) with the four screws (G).
21. Connect the cable to the rear of the box.
22. Replace the operator panel into the Servo Power Module with the four screws.
23. Refer to Chapter 5, "Diagnostic Testing", and load the Verify program.
24. Select option D - "Operator Panel" from the main menu to check the switch function of each switch on the operator panel.

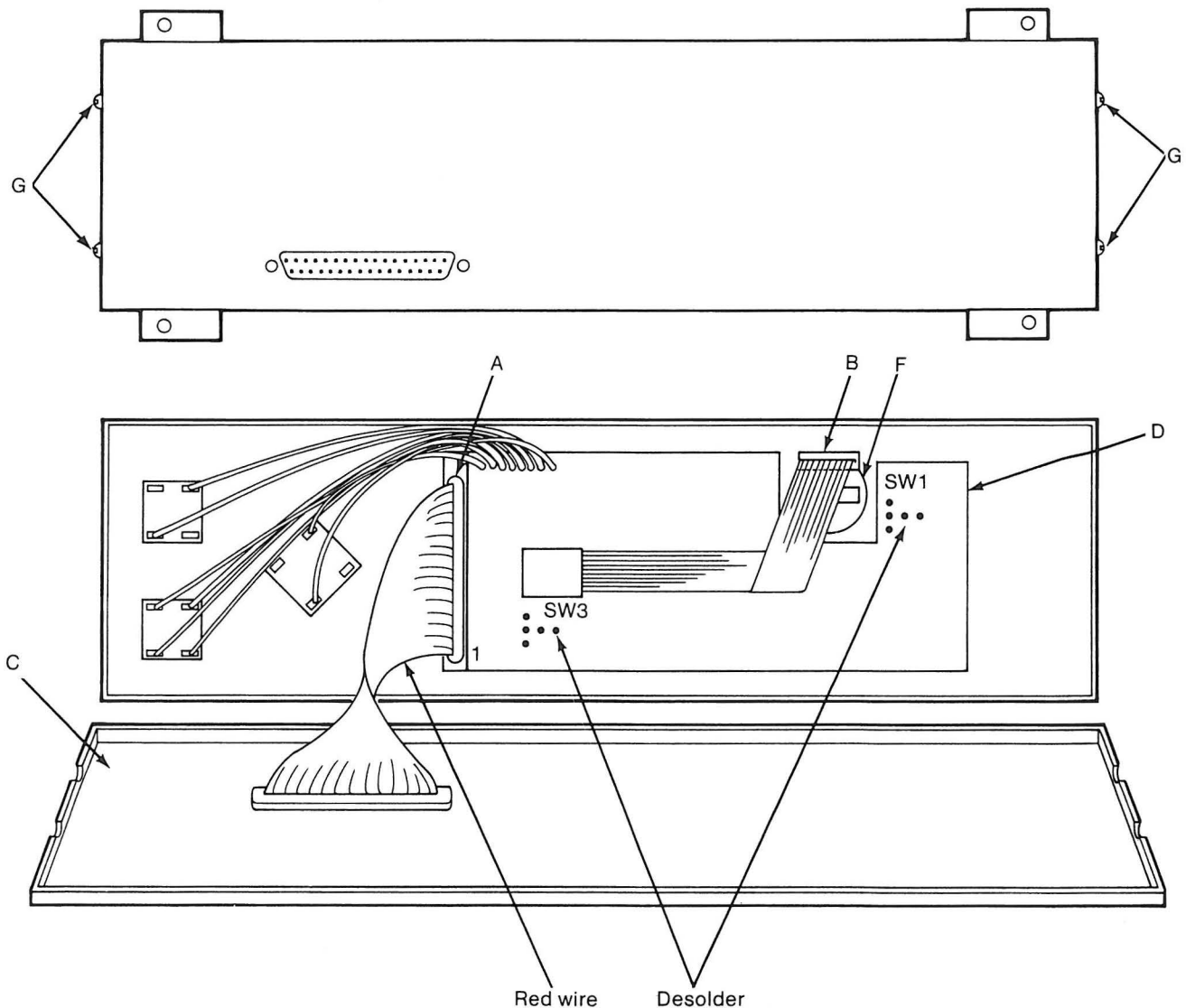

3219 Dynamic Brake Relay

1. Ensure that power has been turned off and removed from all units.
2. Remove the Servo Power Module front cover.
3. Remove the operator panel (see 3213).
4. Disconnect each lead from the terminals on the relay (A), marking each with its location for replacement.
5. Remove the two screws (B) holding the relay (A) to the rear panel and remove the relay.
6. For replacement, reverse the above procedure.

The dynamic brake relays are located behind the operator control panel.

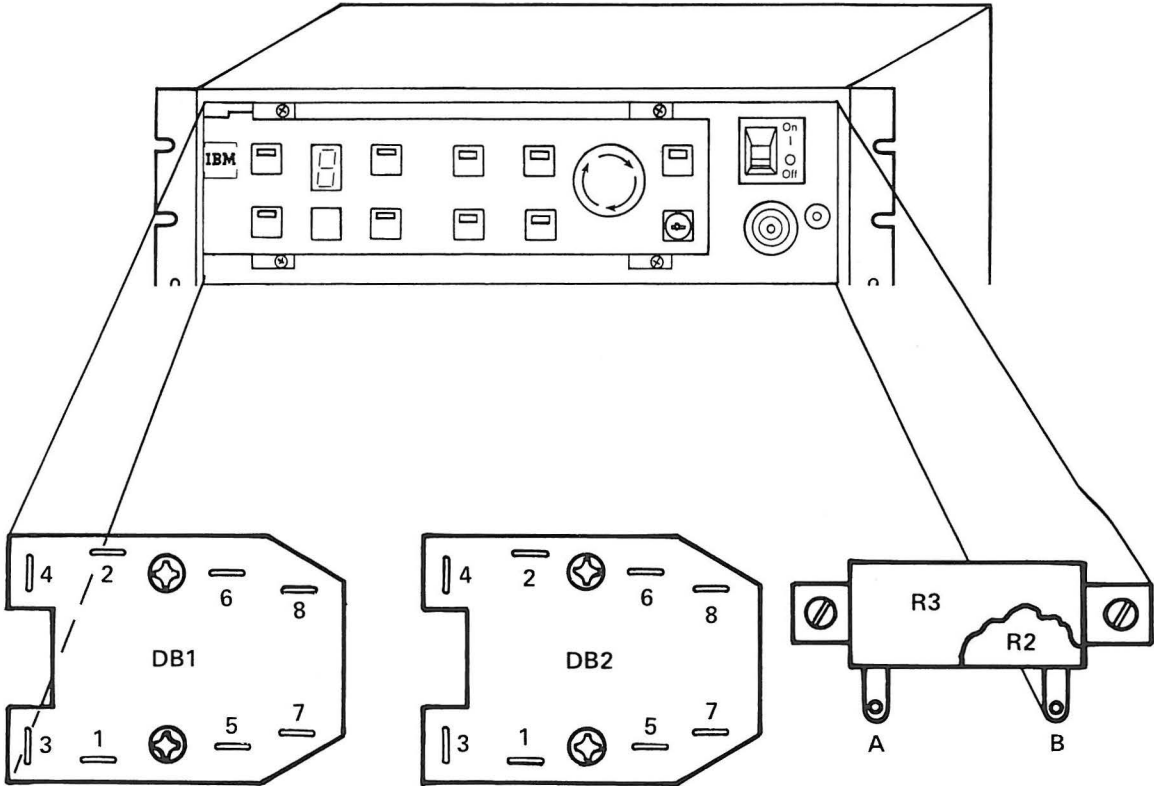

3220 Capacitor C1

1. Ensure that all power has been turned off and removed from all units.
2. Remove the Servo Power Module front cover.
3. Remove all servo amplifier cards (B) and the power supply (A).
4. Mark the locations of the card sockets on the card cage to ensure their proper location when reinstalling.
5. Remove the screws (C) from the servo amplifier card sockets.
6. Mark the location of the capacitor base plate on the card cage to ensure the proper location when reinstalling.
7. Remove the screws (D) from the capacitor base plate.
8. Remove the red wire (+) and black wire (-) from the + and - terminals (E) on the silicon power rectifier.
9. Carefully pull the capacitor and the servo amplifier card sockets out from the card cage to gain access to the power bus connections. Feed the red and black wires from the silicon power rectifier behind the card cage as the capacitor and sockets are pulled.
10. Disconnect the short red and black wires from the power bus.
11. Remove the capacitor.
12. To install the capacitor, reverse the procedure.

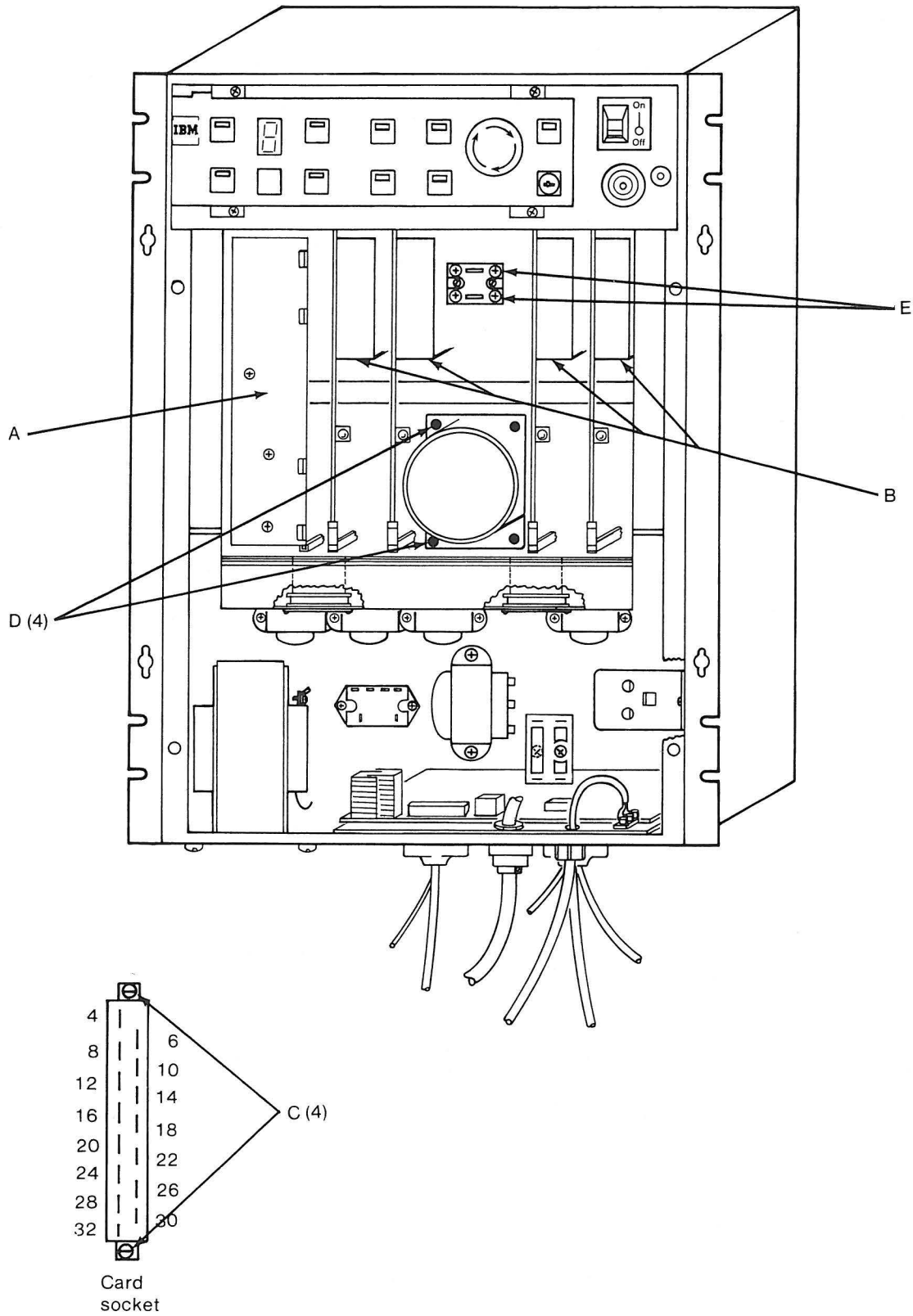

3221 Power On/Off Switch

DANGER

THIS PROCEDURE REQUIRES THE TECHNICIAN TO REMOVE THE 230 VAC INPUT WIRING. THE 230 VAC MUST BE OFF AND DISCONNECTED AT THE POWER SOURCE PRIOR TO STARTING THIS PROCEDURE. TURNING OFF THE SWITCH IS NOT SUFFICIENT.

1. Ensure that power has been turned off and removed from all units.
2. Remove the Servo Power Module front cover.
3. Remove the four screws holding the operator panel and pull the operator panel from the Servo Power Module (3213).
4. Disconnect the cable from the rear of the operator panel and set the operator panel aside.
5. Remove the four screws from the front panel around the power switch bezel.
6. Pull the power switch assembly out through the back of the front panel.

Note: Mark the wire locations to ensure the proper connections during installation.

7. Remove the wires from the power switch terminals.
8. Remove the two screws holding the switch from the back.
9. Remove the switch.
10. For replacement, reverse the procedure.

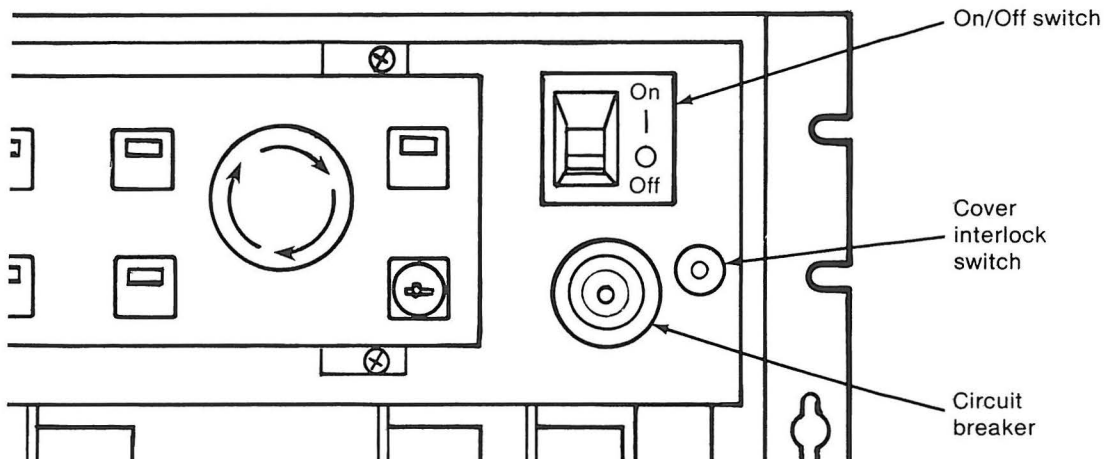

3222 Cover Interlock Switch

DANGER

THIS PROCEDURE REQUIRES THE TECHNICIAN TO WORK AROUND THE 230 VAC INPUT WIRING. THE 230 VAC MUST BE OFF AND DISCONNECTED AT THE POWER SOURCE PRIOR TO STARTING THIS PROCEDURE. TURNING OFF THE SWITCH IS NOT SUFFICIENT.

1. Ensure that power has been turned off and removed from all units.
2. Remove the Servo Power Module front cover.
3. Remove the four screws holding the operator panel and pull the operator panel from the Servo Power Module (3213).
4. Disconnect the cable from the rear of the operator panel and set the operator panel aside.
5. Remove the four screws from the front panel around the power switch bezel.
6. Pull the power switch assembly out through the back of the front panel.

Note: Mark the wire locations to ensure the proper connections during installation.

7. Remove and mark the wires from the interlock switch terminals.
8. Release the spring clips holding the switch and pull the switch out from the front of the bracket.
9. For replacement, reverse the procedure.

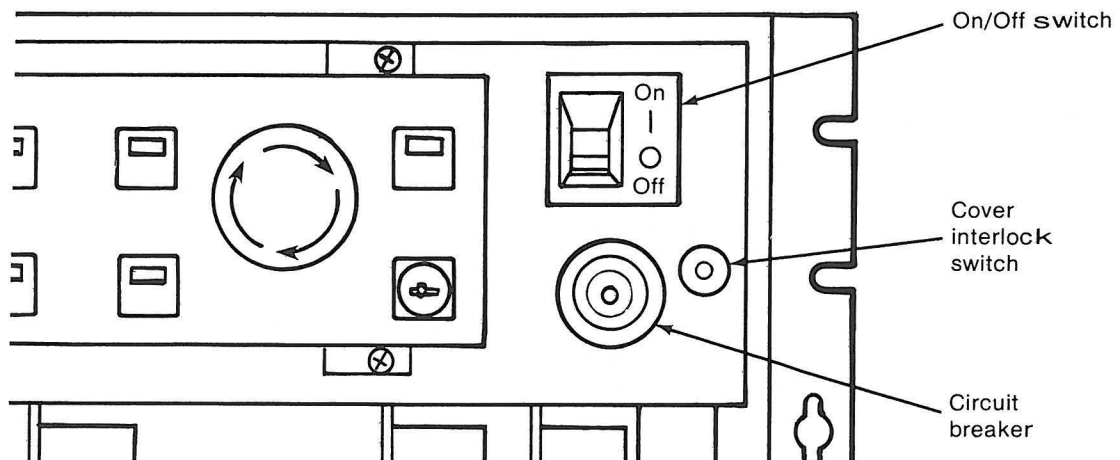

3223 Circuit Breaker

DANGER

THIS PROCEDURE REQUIRES THE TECHNICIAN TO REMOVE THE 230 VAC INPUT WIRING. THE 230 VAC MUST BE OFF AND DISCONNECTED AT THE POWER SOURCE PRIOR TO STARTING THIS PROCEDURE. TURNING OFF THE SWITCH IS NOT SUFFICIENT.

1. Ensure that power has been turned off and removed from all units.
2. Remove the Servo Power Module front cover.
3. Remove the four screws holding the operator panel and pull the operator panel from the Servo Power Module (3213).
4. Disconnect the cable from the rear of the operator panel and set the operator panel aside.
5. Remove the four screws from the front panel around the power switch bezel.
6. Pull the power switch assembly out through the back of the front panel.

Note: Mark the wire locations to ensure the proper connections during installation.

7. Remove the wires from the circuit breaker terminals.
8. Remove the nut holding the circuit breaker.
9. Remove the circuit breaker.
10. For replacement, reverse the procedure.

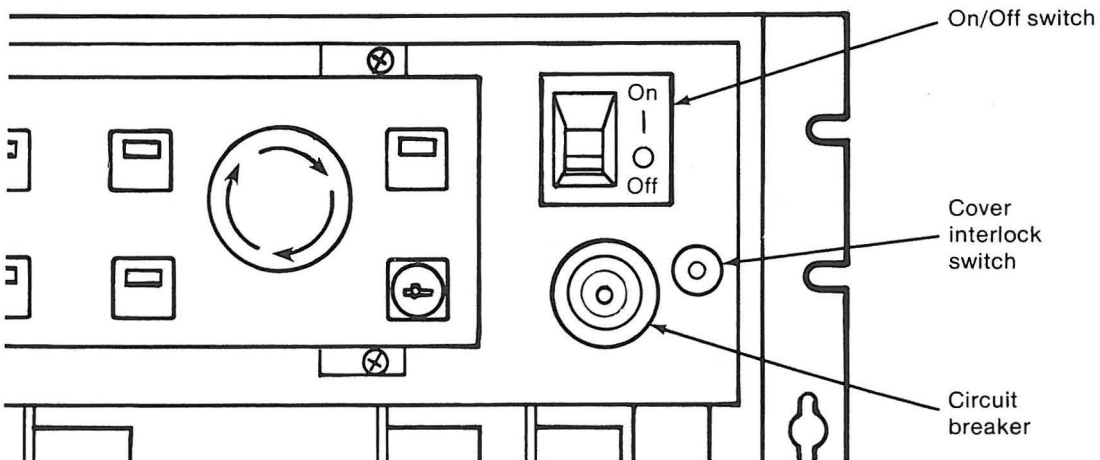

3300 MANIPULATOR REMOVALS AND REPLACEMENTS

3301 Manipulator Cover Removals and Replacements

All covers are designed to be removed and replaced easily, without special instructions.

1. Before removing any cover, ensure that power has been turned off and removed from all units.
2. If necessary, refer to the appropriate figures or to the "Locations" section and remove/replace covers.

3302 Axis Sensors Removals and Replacements

Note: Consider that the home positions may be lost whenever removing and replacing a home sensor.

1. Ensure that power has been turned off and removed from all units.
2. Refer to the "Locations" section and remove the appropriate covers for access to the proper sensor(s).
3. Remove the appropriate sensor(s).
4. After replacing, refer to the "Axis Home Adjustment" procedures (4008) for the necessary calibration.
5. Replace the appropriate covers when completed.

3303 Z-Shaft Removal

Note: Consider that Z home and payload position will be lost.

1. Ensure that power has been turned off and removed from all units.
2. Turn off the compressed air source.
3. Remove any payload attached to the Z-shaft.
4. Remove the Z-shaft and roll belt covers.
5. Remove the bracket (A) from the air hose (C) and the Z-axis ball screw block (B).
6. Disconnect the air hose (C). While holding the circular nut (F), remove the air hose fitting (E).
7. Loosen the set screws. While holding the roll axis pulley (J), loosen the circular nut (F) on the Z-shaft (H).
8. Loosen the roll belt tensioner arms (G).
9. Remove the Z-shaft pulley (J) screws; then remove the pulley (J) and belt (K).

Note: The Z-shaft and the ball spline are a matched set, and they must be kept matched "spline to slot" exactly as they were originally assembled. When replacing the Z-shaft with a new one, the ball spline must also be replaced and should be part of the new Z-shaft assembly.

10. Mark one spline of the Z-shaft (H) and its mated ball spline (L) slot for correct matching during replacement, if you are replacing the same Z-shaft.

CAUTION

Secure the Z-shaft so that it does not fall out of the Z-head when the next step is performed.

Note: Each set screw has a brass insert to protect the threads. Do not lose the brass inserts when replacing the nut.

11. Remove the circular nut (F) and the Z-shaft (H).
12. If replacing the Z-shaft with a new one, go to the "Z-Shaft Ball Spline and Bearing Removal" procedure (3307).

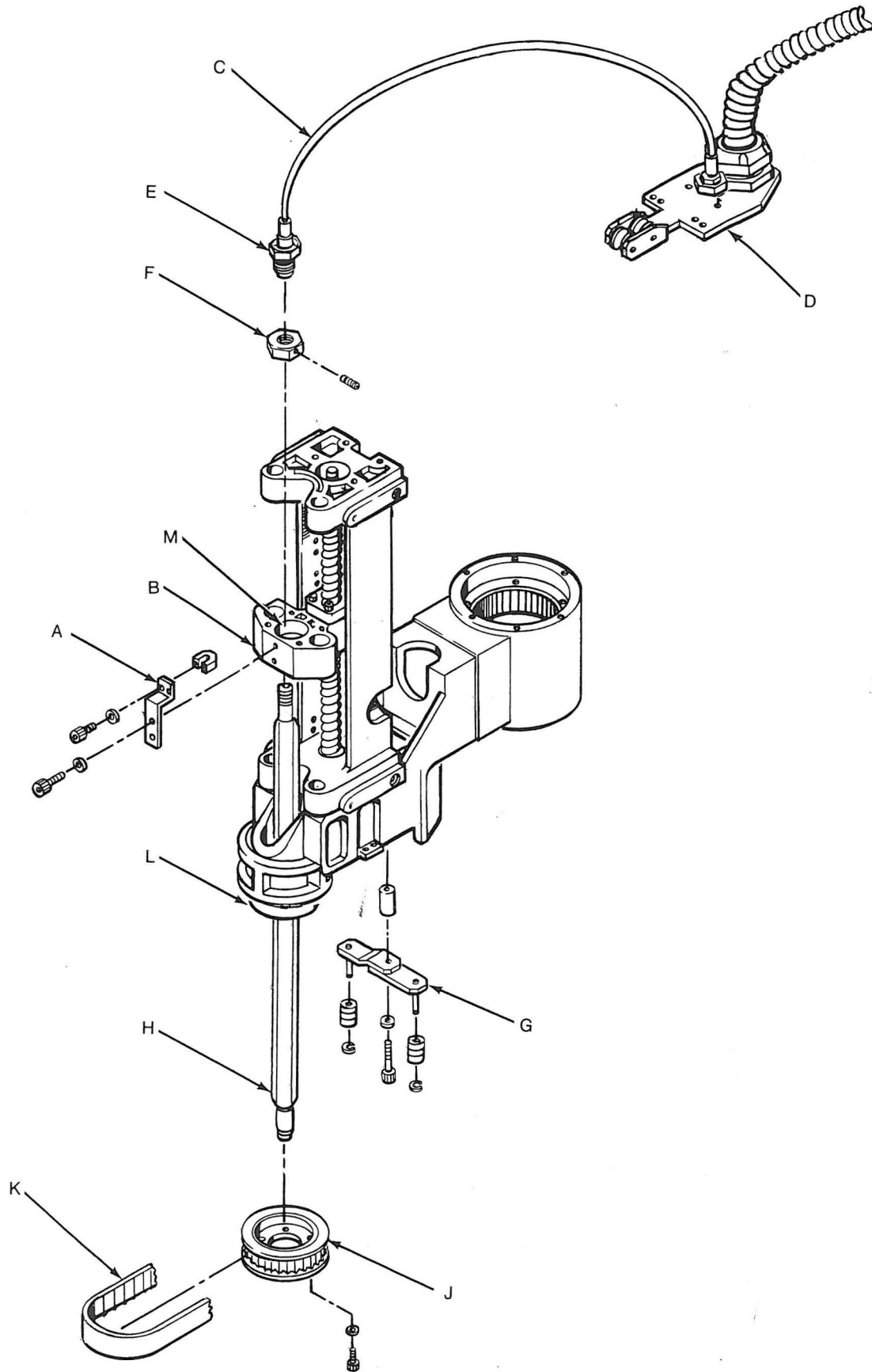

3304 Z-Shaft Replacement

CAUTION

Do not disturb the spline ball bearings when inserting the Z-shaft.

1. Perform the "Z-Shaft Ball Spline and Bearing Replacement" procedure (3308), if necessary.
2. Align the marked spline on the Z-shaft (H) with the marked slot in the lower ball spline assembly (L). Carefully install the Z-shaft in both the lower ball spline assembly and the Z-shaft upper bearing (M).

Note: Each set screw has a brass insert to protect the threads. Do not lose the brass inserts when replacing the nut.

3. Replace the circular nut (F).
4. Replace the Z-shaft pulley (J) and belt (K).
5. While holding the roll axis pulley, tighten the circular nut (F) and then the set screws in the nut.
6. While holding the circular nut (F) replace the air hose fitting (E).
7. Connect the air hose (C) and install the bracket (A) on the block (B) and to the air hose.
8. Perform the roll driven belt adjustment (4008).
9. Replace the roll belt and Z-shaft covers.
10. Replace any payload previously removed and calibrate.
11. Refer to the "Axis Home Adjustment" procedure (4008) for the necessary calibration.

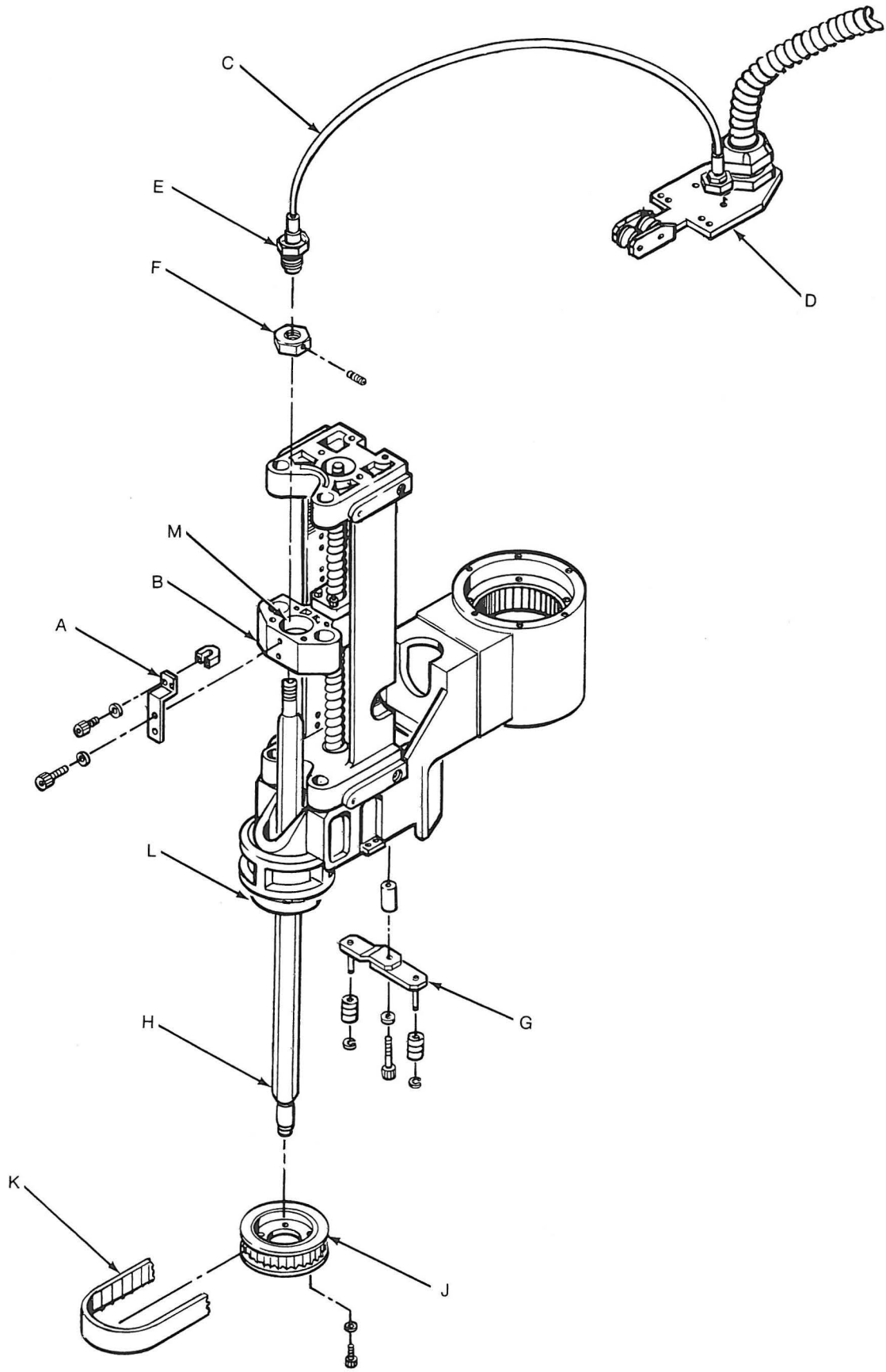

3305 Z-Shaft Upper Bearing Removal

1. Ensure that power has been turned off and removed from all units.
2. Remove the Z-shaft and roll belt covers.
3. Perform the "Z-Shaft Removal" procedure (3303), steps 4 through 7. Instead of removing the Z-shaft (D), simply lower it through the upper bearing block (A) and replace the circular nut (E), finger tight, to prevent removal. This will also save payload position.
4. Remove the four bearing cap screws and remove the bearing cap (B).

Note: Observe the position of the bearing races in relation to each other for correct replacement.

5. Remove the two bearings (C) upward out of the block assembly (A).

3306 Z-Shaft Upper Bearing Replacement

Note: On the side of each bearing is an arrow that must be retained in order and pointing down during installation.

1. Insert the two bearings (C) with the open races facing each other into the block assembly (A). Light tapping is required.
2. Replace the upper bearing cap (B)
3. Perform the "Z-Shaft Replacement" procedure (3304), steps 2 through 8.
4. Replace the Z-shaft and roll belt covers.

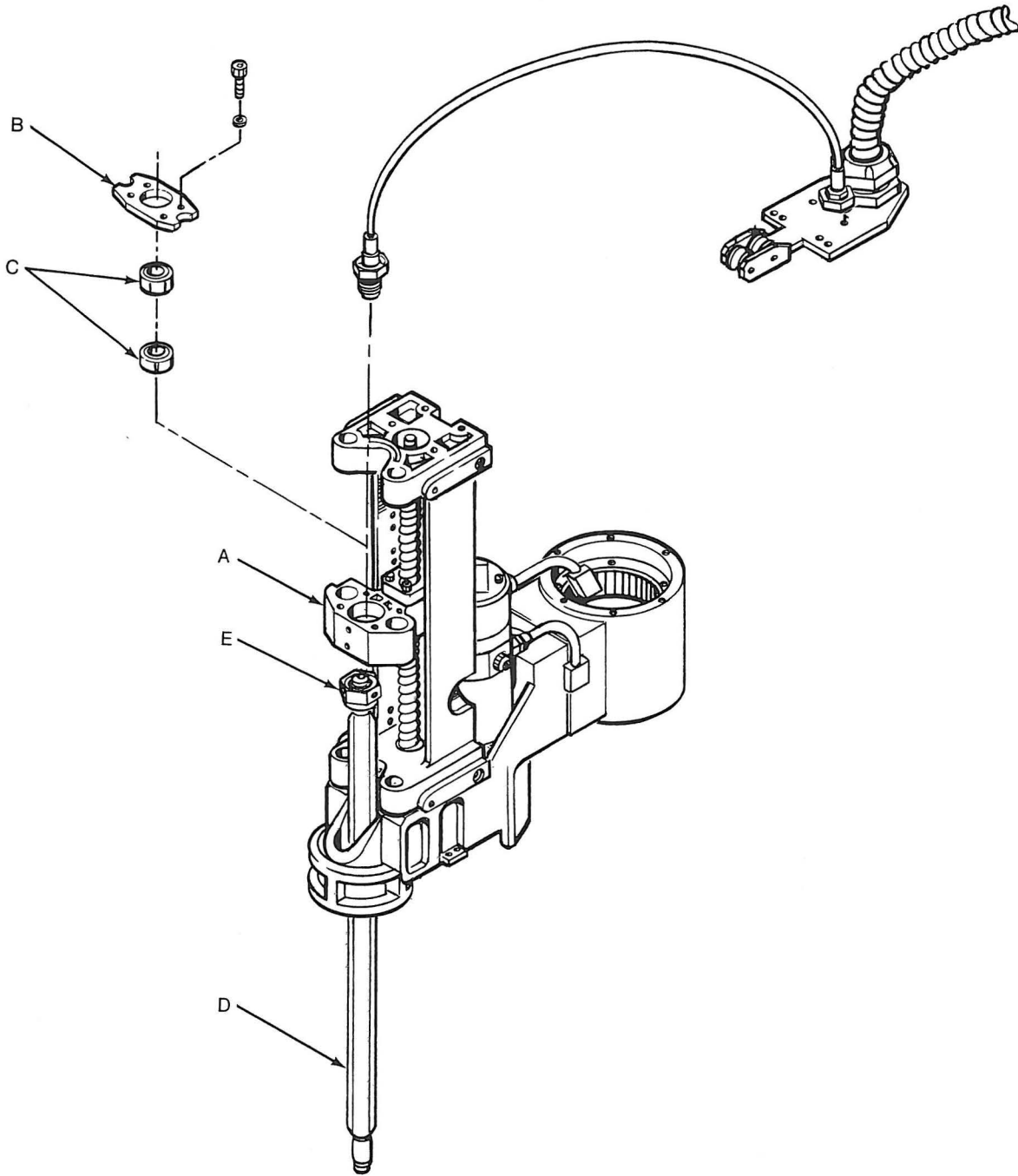

3307 Z-Shaft Ball Spline And Bearing Removal

Note: Consider that Z home and payload position will be lost.

1. Ensure that power has been turned off and removed from all units.

Note: The Z-shaft (B) and the ball spline (C) are a matched set, and they must be kept matched "spline to slot" exactly as they were originally assembled. When replacing the ball spline with a new one, the Z-shaft must also be replaced.

2. Perform the "Z-Shaft Removal" procedure (3303).
3. Remove the bearing cap screws (D), and slide the spline assembly (C) downward and out of the Z-head (A).

3308 Z-Shaft Ball Spline And Bearing Replacement

1. Slide the spline assembly (C) upward, into the Z-head (A), and install the bearing cap screws (D).
2. Perform the "Z-Shaft Replacement" procedure (3304).
3. Refer to the "Axis Home Adjustment" procedure (4008) for the necessary calibration.

Figure 3307, 3308

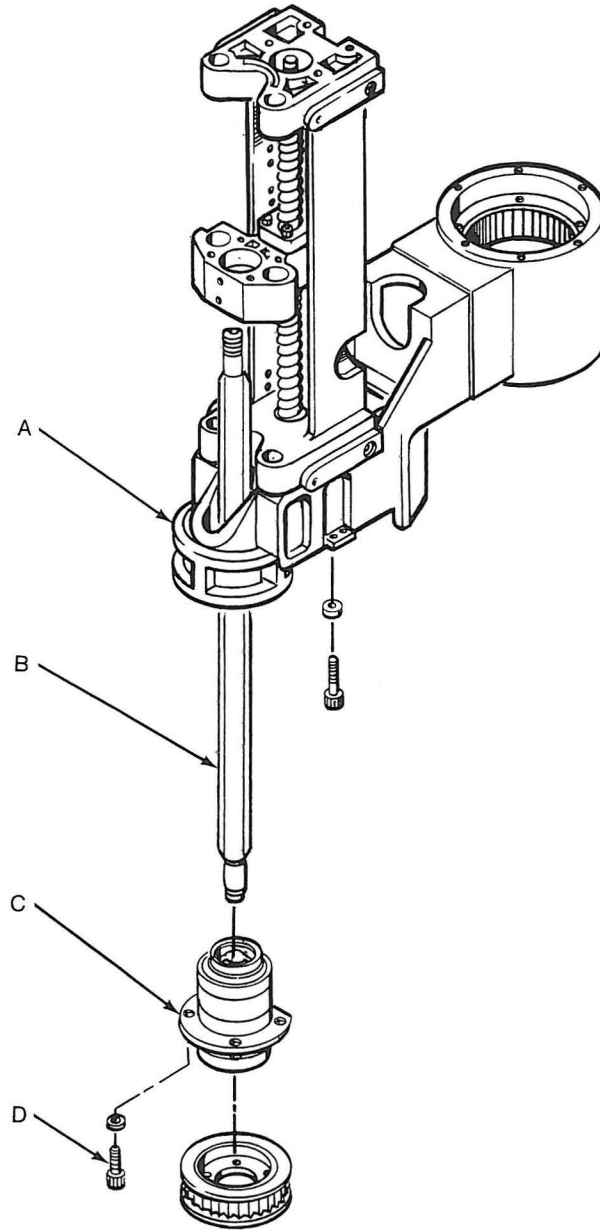

3309 Z-Axis Ball Screw Removal

Note: Consider that Z home and payload position will be lost.

1. Ensure that power has been turned off and removed from all units.

Note: The payload must be removed from the Z-shaft before proceeding.

2. Remove the Z-shaft and roll belt covers.
3. Perform the "Z-Shaft Removal" procedure (3303), steps 4 through 7. Instead of removing the Z-shaft (D), simply lower it through the upper bearing block (B) and replace the circular nut (C) finger tight to prevent removal. This will also save payload position.
4. Remove the cable bracket (A) and ground wire from the top of the the Z-axis casting.
5. Remove the screws holding the brake bracket assembly (F) to the Z-head and remove the brake bracket assembly (F)
6. Remove Z-Axis sensors (H). Note the position of each for replacement.
7. Remove the four screws (E) that hold the ball screw casting
8. Tilt the ball screw assembly (J) away from the motor (G) and slip the belt (N) off of the pulley (M).
9. The ball screw assembly FRU (J) can now be lifted out.

Note: Each set screw has a brass insert to protect the threads. Do not lose the brass inserts when replacing the nut.

10. Loosen the set screws and remove the circular nut (L) from the ball screw shaft.
11. Remove the two set screws from the pulley (M) and remove the pulley (M) from the ball screw shaft.
12. Remove the vertical guide bars (K), if necessary.

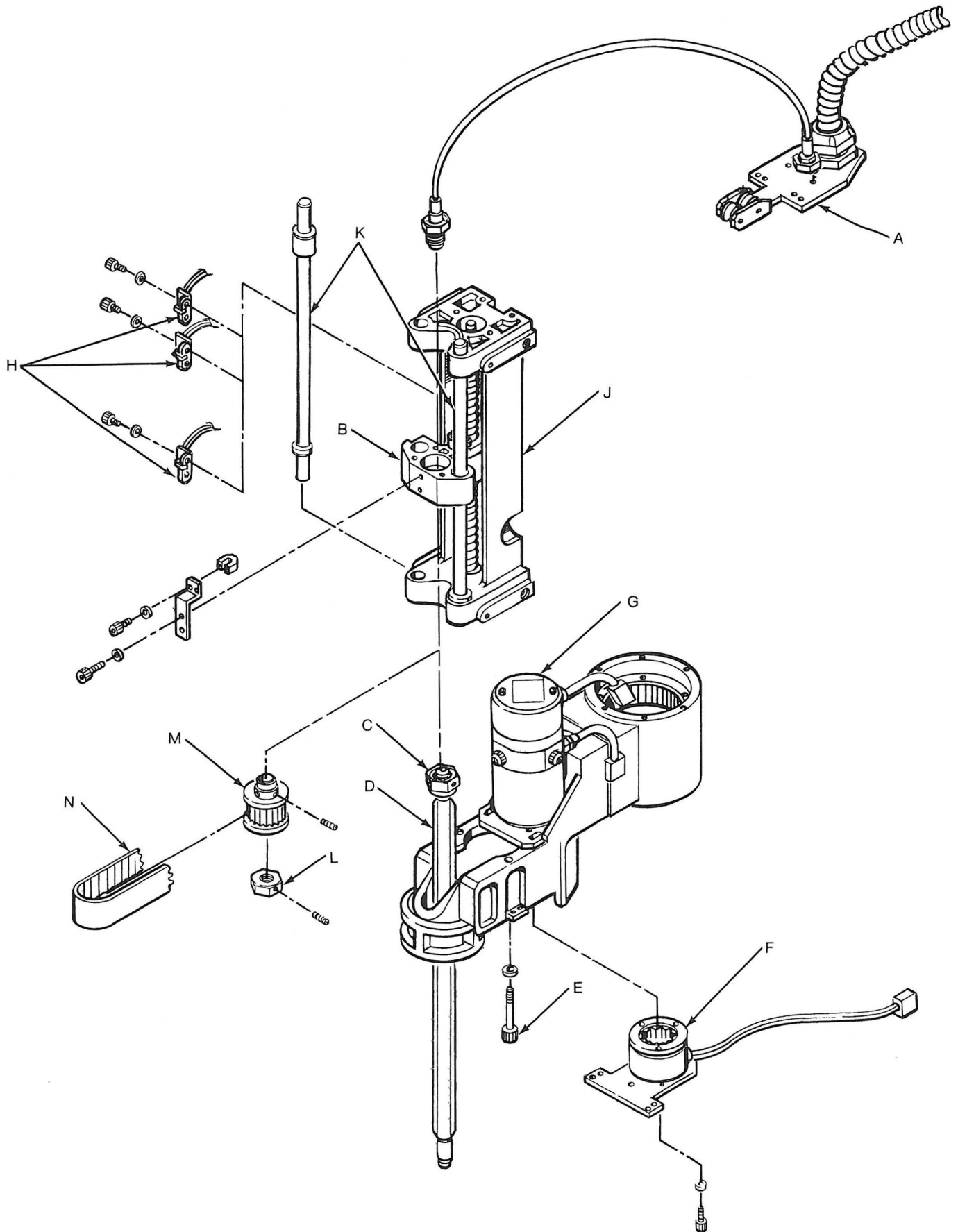

3310 Z-Axis Ball Screw Replacement

1. Replace the vertical guide bars (K), if necessary.
2. Replace the ball screw pulley (M), if necessary.
3. Replace the circular nut (L) and tighten. Tighten the set screws.
4. Set the Z-axis ball screw assembly (J) on the Theta 2 arm casting and tilt away from the motor (G).
5. Slide the Z-axis belt (N) over the motor pulley and the Z-axis ball screw pulley.
6. Install the ball screw assembly with the four ball screw casting screws (E) and tighten.
7. Replace the Z-Axis sensors (H).
8. Perform the "Z-Axis Brake Replacement" procedure (3312) (F).
9. Replace the cable bracket (A) and ground wires.
10. Perform the "Z-Shaft Replacement" procedure (3304) steps 2 through 4.
11. Perform the "Roll Driven Belt" procedure (4016).
12. Replace the Z-shaft and roll belt covers.
13. Refer to the "Axis Home Adjustment" procedure (4008) for the necessary calibration.

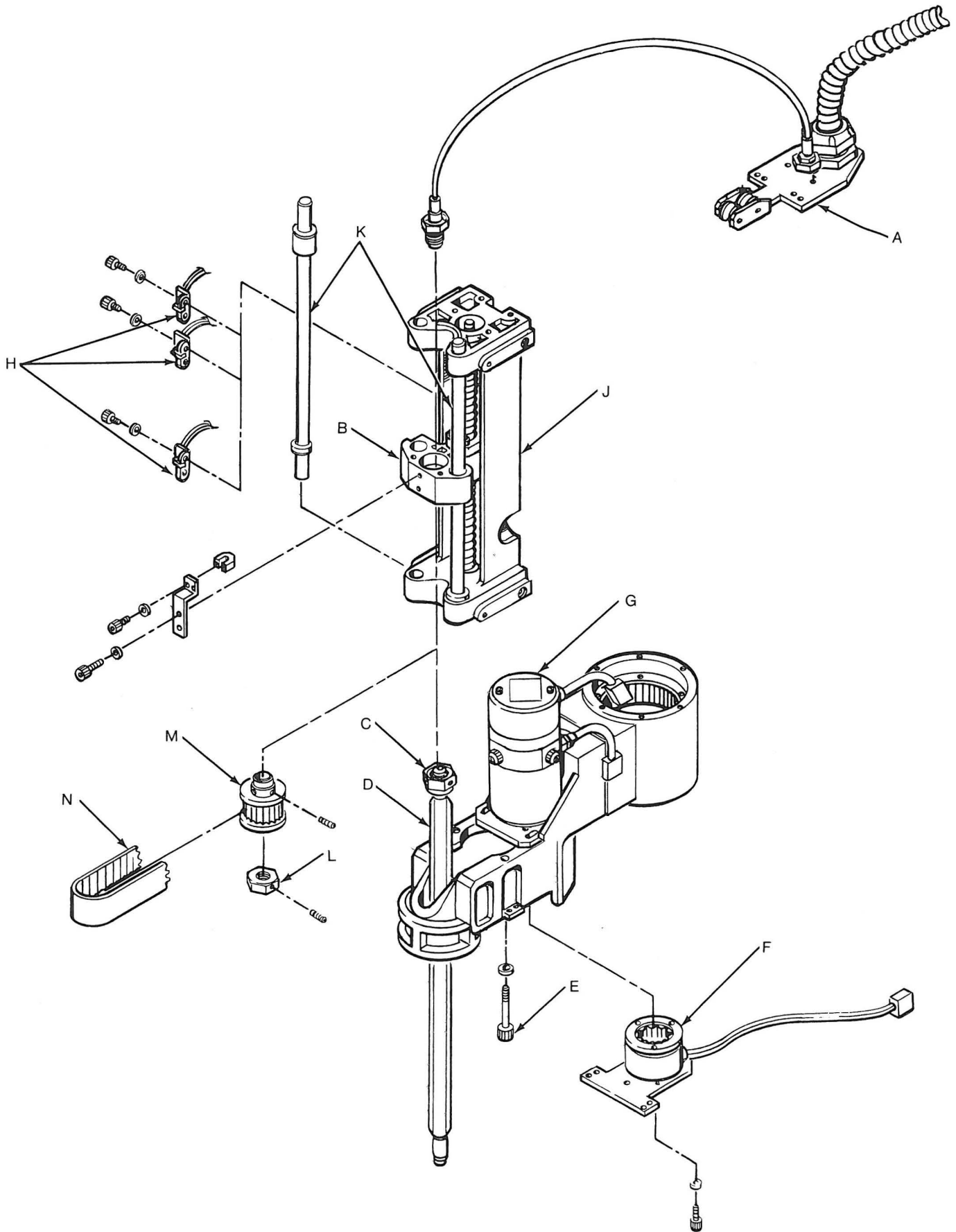

3311 Z-Axis Brake Removal

1. Ensure that power has been turned off and removed from all units.
2. Remove any payload attached to the Z-shaft, if necessary.
3. Remove the Z-shaft and roll belt covers, if necessary.
4. Loosen the belt tensioner bolt (F) and disengage the roll driven belt.
5. Remove the screws holding the brake bracket (A) to the Z-head and remove the bracket and the brake (B) together.
6. Remove the brake (B) from bracket (A), and disconnect the cable (E), if necessary.

3312 Z-Axis Brake Replacement

1. Mount the brake (B) on the bracket (A), if previously removed.

CAUTION

The splined pulley shaft (C) must be fully seated in the brake assembly spline disc (D) for proper operation.

2. Route the brake cable (CN20H) up through the Z-head casting and install the bracket and the brake together, engaging the splined pulley shaft (C) into the brake spline disc (D) fully.
3. Move the Z-shaft up and down slightly until the brake locks the Z-shaft. Tighten the brake mounting bracket screws (A).
4. Connect the brake cable (E), if previously disconnected.

Note: If coming to this procedure from another procedure, return to the original procedure at this point.

5. Perform the "Roll Driven Belt" procedure (4016).
6. Replace the roll belt cover.
7. If Z axis operation is noisy, refer to "Z-Axis Brake Adjustment" (4019).

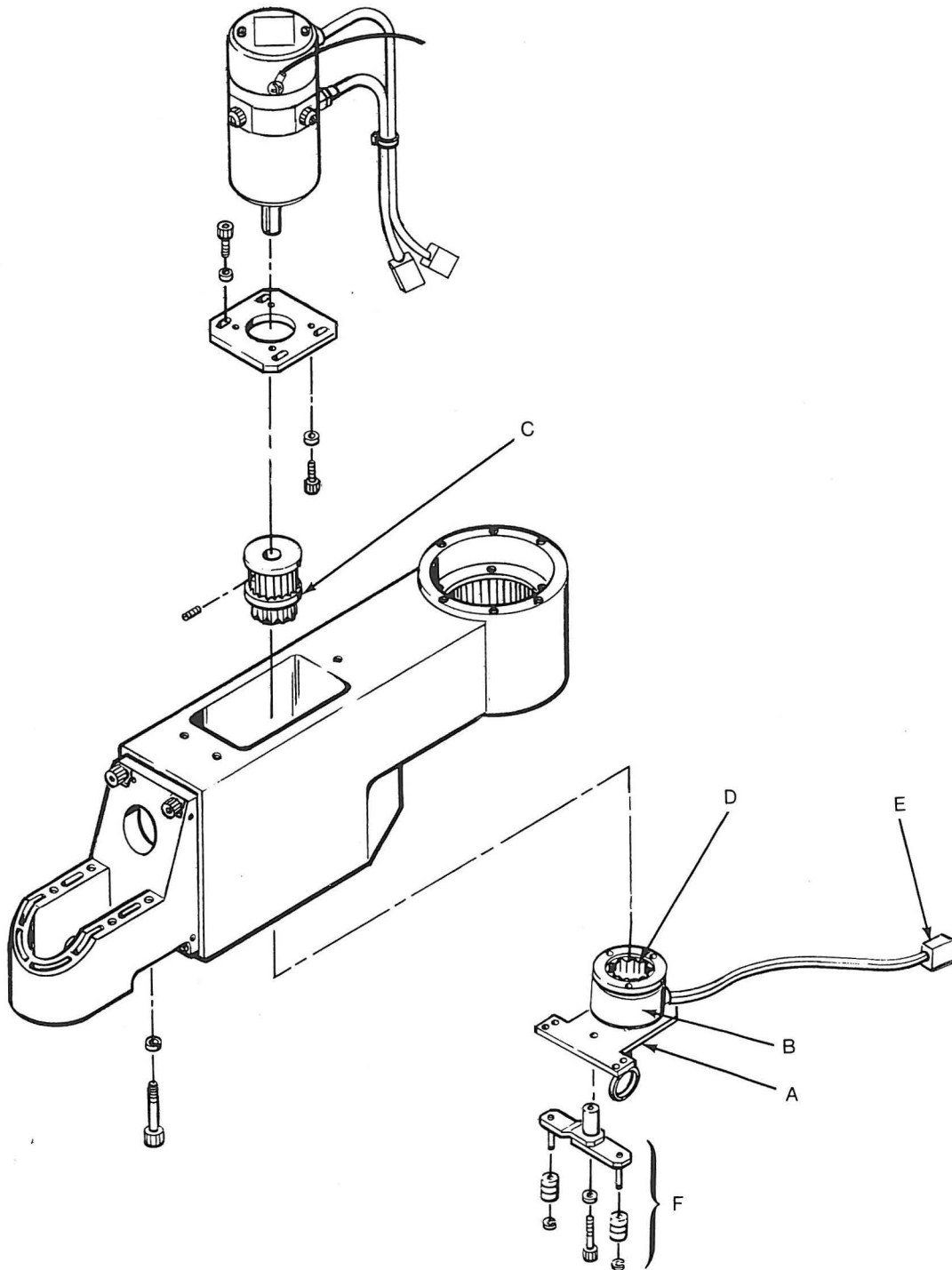

3313 Z-Axis Ball Screw Bearing Removal

Note: Consider that Z home and payload position will be lost.

Note: It is recommended that when upper or lower ball screw bearings require replacement, the ball screw assembly as a whole should be replaced.

1. Ensure that power has been turned off and removed from all units.
2. Remove the Z-shaft and roll belt covers.
3. Perform the "Z-Axis Ball Screw Removal" procedure (3309), steps 1 through 11.
4. Remove the lower bearing retaining plate (F) from the bottom of the casting (D).
5. Pull the Z-axis ball screw (C) out through the lower bearing (E) hole.

Note: The lower bearings must be installed on the ball screw shaft in the same direction as they were removed. Mark the direction on the bearings prior to removal.

6. Remove the lower bearings (E) with a bearing puller if necessary.
7. Remove the snap ring (A) on the top of the ball screw shaft (C) and pull the upper bearings (B) from the shaft, if necessary.

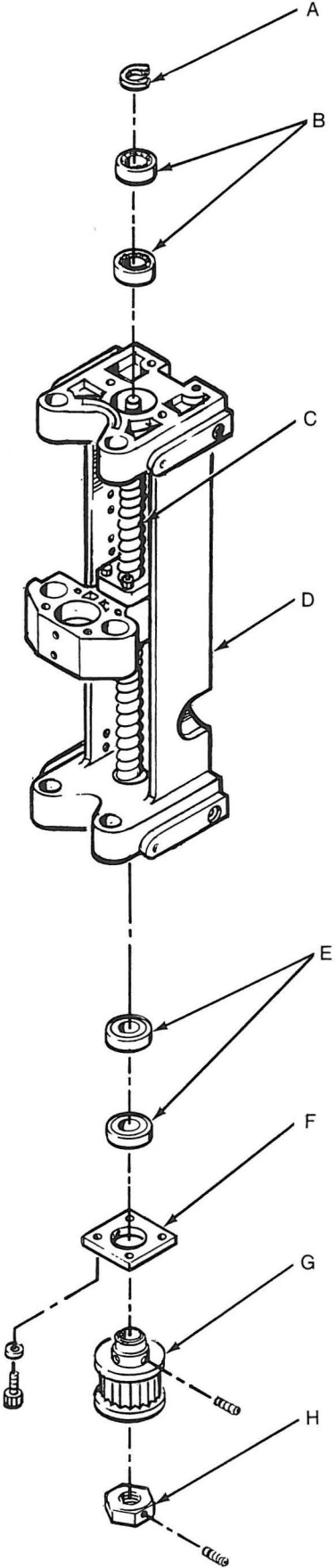

3314 Z-Axis Ball Screw Bearing Replacement

Note: Ensure that the lower bearings are installed on the ball screw shaft in the proper order.

1. Install the bearings (B) and (E) on the shaft.
2. Replace retaining ring (A) on the upper end of the ball screw shaft (C).
3. Slide the ball screw shaft (C) and bearings (B) and (E) into position in the casting.
4. Install the lower bearing retainer plate (F).

Note: Install the pulley with the collar up.

5. Install the Z-axis ball screw pulley (G) and tighten the set screws.

Note: Each set screw has a brass insert to protect the threads. Do not lose the brass inserts when replacing the nut.

6. Install the circular nut (H) and tighten. Tighten the set screws.
7. Perform the "Z-Axis Ball Screw Replacement" procedure (3310), steps 3 through 12.

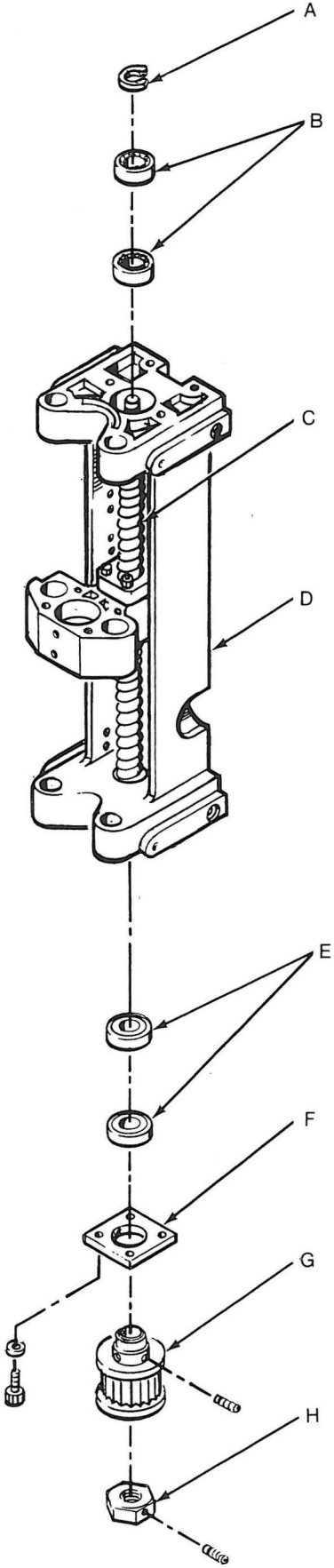

3315 Z-Axis Motor and Brush Removal (7575 only)

Note: Consider that Z home and payload position will be lost if the motor is removed.

Note: For brush removal only, perform steps 1 through 3.

1. Ensure that power has been turned off and removed from all units. Remove the payload, if necessary.
2. Remove the Z-shaft and roll belt covers.
3. Remove the motor brushes (D), if necessary.
4. Perform "Z-Axis Brake Removal" procedure (3311), steps 1 through 4.
5. Disconnect the two motor cables (CN21H and CN22H) and the ground wire (C).
6. Remove the motor bracket (B) screws.
7. Move the motor (A) away from the Z-shaft to disengage the belt (G), lift upward and away from the Z head.
8. Note the clearance between the motor pulley and the motor body.
9. Loosen the set screws and remove the pulley (F).
10. Remove the motor bracket (B) from the motor (A), if necessary.

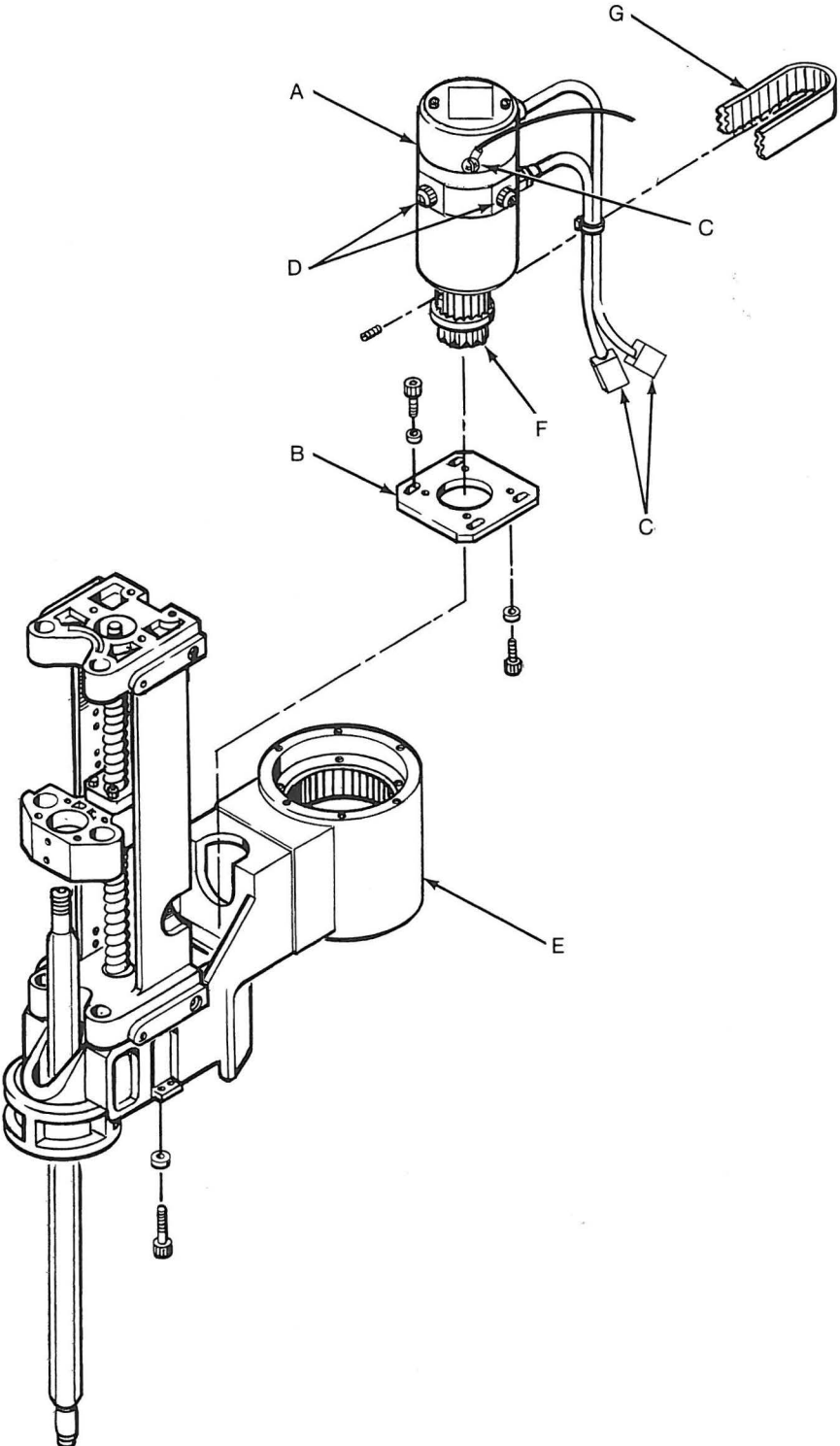

3316 Z-Axis Motor and Brush Replacement (7575 only)

Note: For brush replacement only, perform step 7 after new brushes are installed.

1. Attach the motor (A) to the motor bracket (B).
2. Position the pulley (F) on the motor shaft allowing the clearance noted in the removal procedure. If that clearance is unknown, position the pulley 0.030 inch clearance (± 0.005 inch) between the top of the pulley and the bottom of the motor bracket, then tighten the set screws in the pulley (F) .
3. Slip the belt (G) over the pulley (F) as the motor (A) is placed in the Z head casting.
4. Install the motor bracket (B) screws loosely. Slide the base in its slots to tighten the belt and tighten the motor bracket screws (B).
5. Attach the two motor cables and the ground wire (C).
6. Perform the appropriate "Z-Axis Brake Replacement" procedure.
7. Replace the Z-shaft and roll belt covers.
8. Refer to "Axis Home Adjustment" procedure (4008) for the necessary calibration.

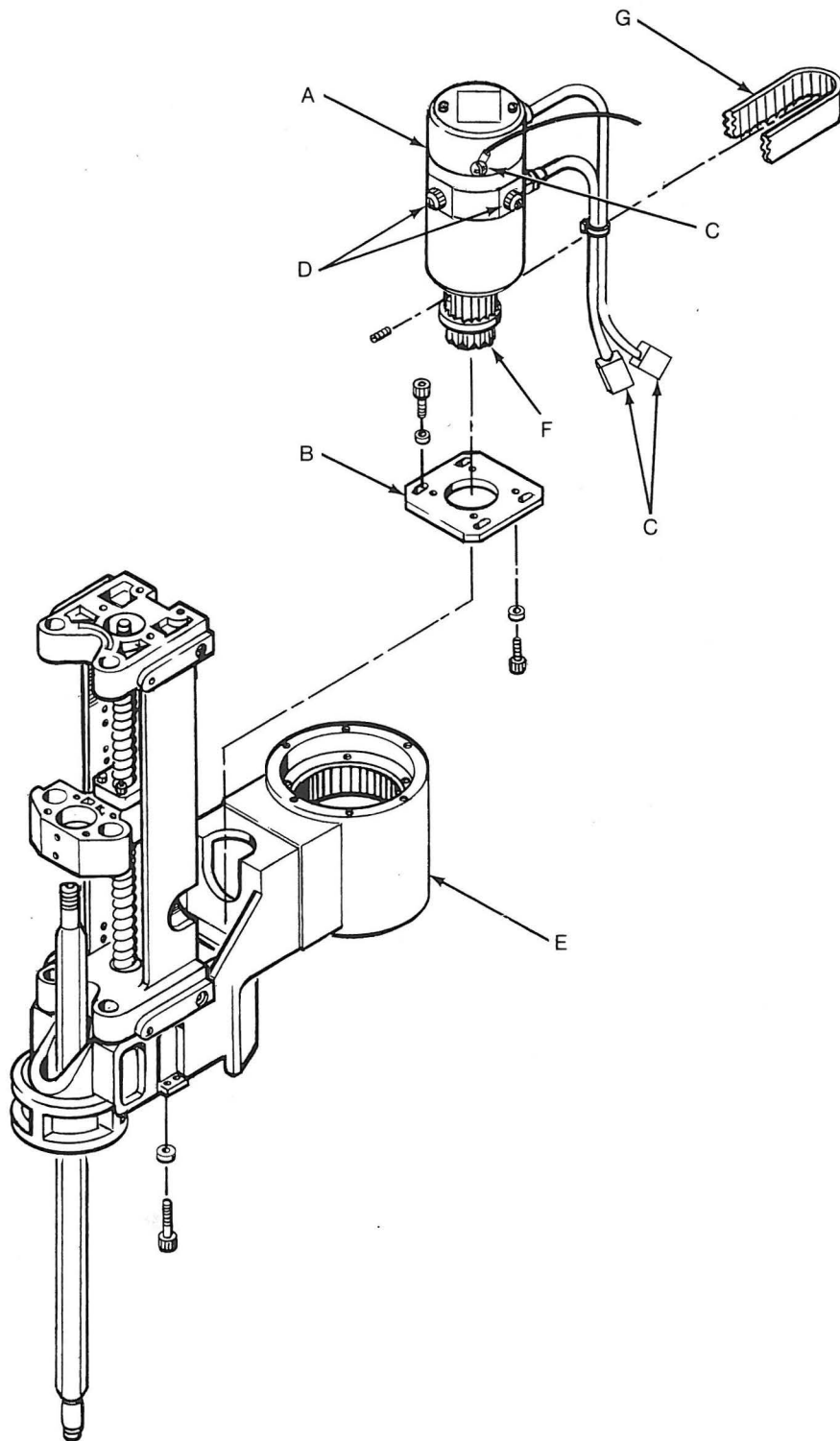

3317 Z-Axis Motor and Brush Removal (7576 only)

Note: Consider that Z home and payload position will be lost if the motor is removed.

Note: If replacing the motor brushes, perform steps 1 and 2 only.

1. Remove the Z motor cover and the cable bracket (E).
2. The Z motor brushes (D) can now be removed and replaced.
3. Remove the roll belt cover.
4. Perform the "Z-Axis Brake Removal" procedure (3311) steps 1 through 4.
5. Remove the motor base screws, push the motor (A) away from the Z shaft to disengage the belt, then remove the motor.
6. Disconnect the two motor cables (C) (CN21H and CN22H) and the ground wire.
7. Remove the motor pulley (F), and the motor base (B), if appropriate.

3318 Z-Axis Motor and Brush Replacement (7576 only)

Note: For brush replacement only, perform only step 7 after installing new brushes.

1. Attach the motor (A) to the motor base (B).
2. Position the pulley (F) on the motor shaft allowing .030 inch clearance ($\pm .005$ inch) between the top of the pulley and the bottom of the motor bracket, then tighten the set screws in the pulley (F).
3. Position the pulley (F) with the belt in place. Then rotate the motor/base assembly (A)/(B) into position while slipping the belt onto the ball screw shaft pulley.
4. Install the motor (A) screws hand tight. Slide the base (B) in its slots to tighten the belt and tighten the motor base screws.
5. Attach the two motor cables and the ground wire (C).
6. Perform the "Z-Axis Brake Replacement" procedure (3312).
7. Replace the Z access and roll belt covers.
8. Refer to "Axis Home Adjustment" procedure (4008) for the necessary calibration.

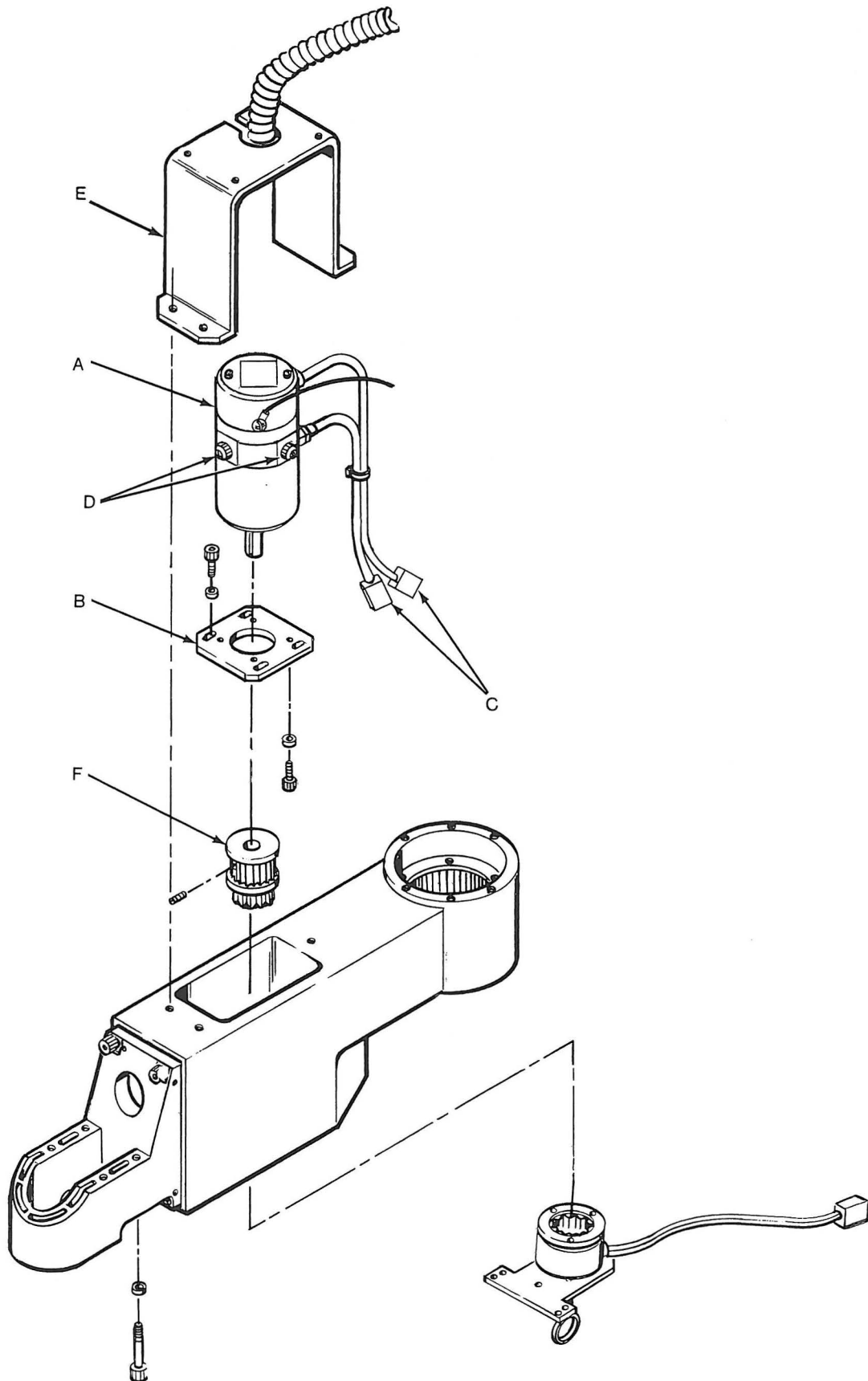

3319 Z-Head/Theta 2 Casting Removal (7575 only)

Note: Consider that Theta 2 home, roll home, Z-axis home, and payload position will be lost.

1. Ensure power has been turned off and removed from all units.
2. Turn off the compressed air source.
3. Remove the Z-shaft covers.
4. Remove the air hose bracket (A) and disconnect the fitting (C) from the top of the Z-shaft.
5. Remove the cable bracket assembly (B), disconnect the appropriate cables and lay the cable bracket assembly aside.
6. Perform the "Theta 2 Harmonic Drive Removal" procedure (3327), which removes the Z-head/Theta 2 casting.
7. To retain any subassembly refer to the appropriate procedure as necessary.

3320 Z-Head/Theta 2 Casting Replacement (7575 only)

1. Perform the "Theta 2 Harmonic Drive Replacement" procedure (3328), which replaces the Z-head/Theta 2 casting.
2. Replace any subassembly that was previously removed. Refer to the appropriate replacement procedure as necessary.
3. Replace the cable bracket assembly (B) and connect all cables.
4. Connect the air hose fitting (C) to the top of the Z-shaft.
5. Replace the air hose bracket (A).
6. Replace the Z-shaft covers.
7. Refer to the "Axis Home Adjustment" procedure (4008) for the necessary calibration.

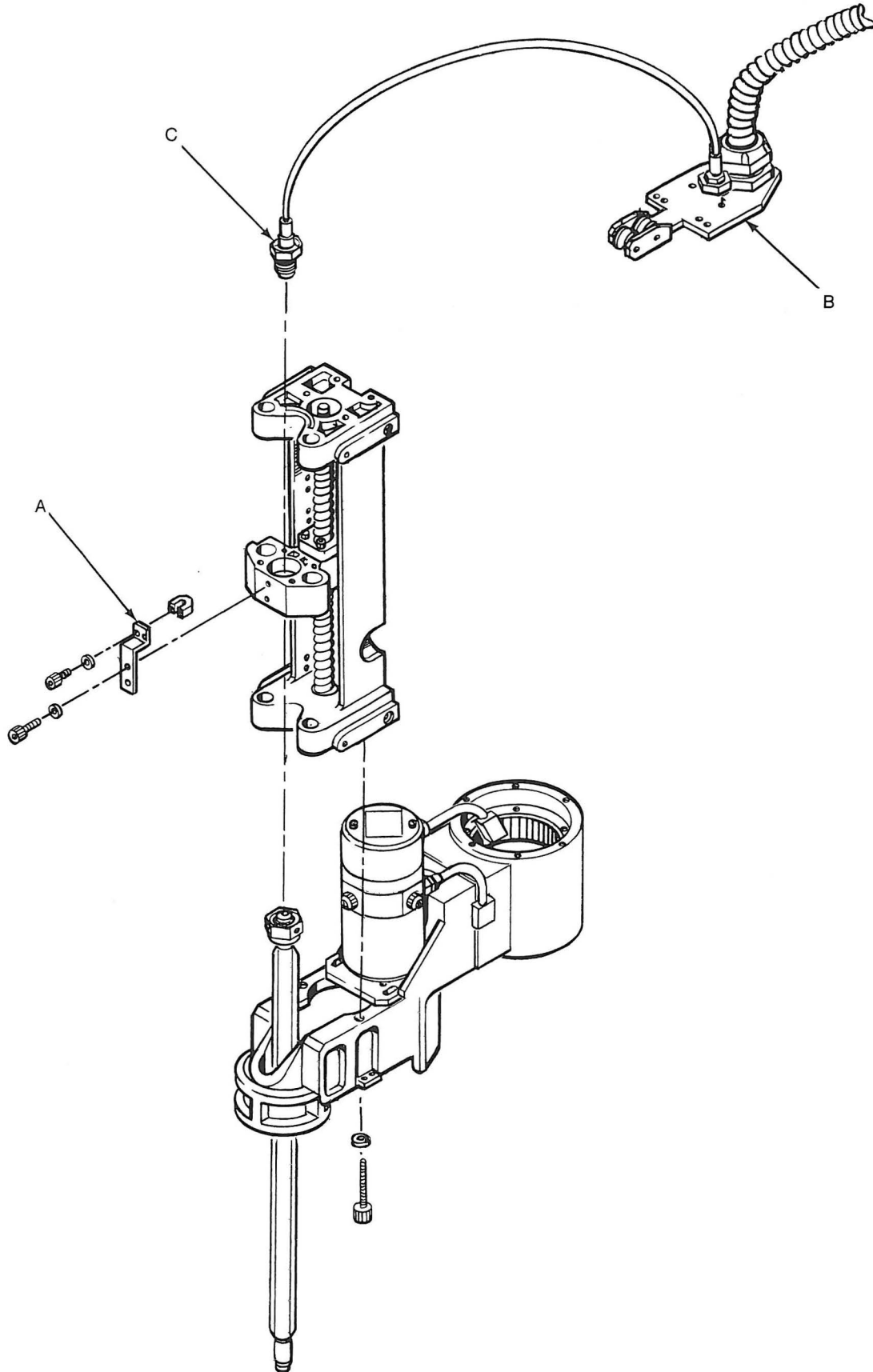

3321 Z-Head Casting Removal (7576 only)

Note: Consider that Z home and payload position will be lost.

1. Ensure power has been turned off and removed from all units.
2. Turn off the compressed air source.
3. Remove the payload if necessary.
4. Remove the Z-shaft and roll belt covers.
5. Pull air hose clamp (A) downward and remove air hose from the bottom of the guide roller bracket.
6. Disconnect the sensor cables (B).
7. Loosen the roll driven belt tensioner arms (F) and remove the belt (D).
8. Perform the "Z-Axis Brake Removal" procedure (3311).
9. Loosen the Z servo motor (C) mounting screws. Slide the motor (C) toward the Z-shaft and remove the motor drive belt.
10. Remove the Z head assembly nuts (G) and lift out the Z head assembly (E).
11. To retain any subassembly refer to the appropriate procedure as necessary.

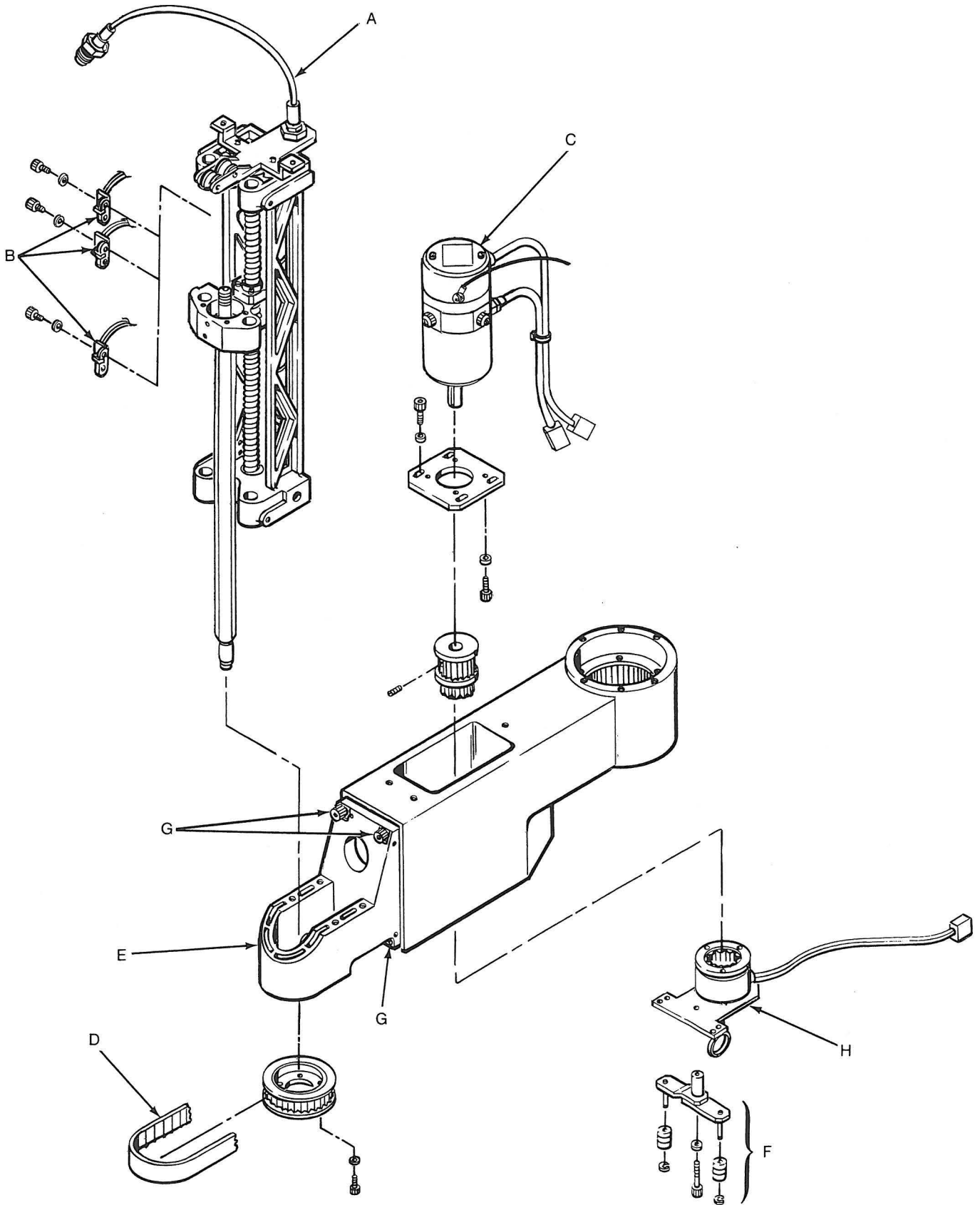

3322 Z-Head Casting Replacement (7576 only)

1. Replace any subassembly that was previously removed. Refer to the appropriate replacement procedure as necessary.
2. Lace the air hose (A) and cables (B) through the slot.
3. Position the Z head assembly (E) onto the Theta 2 casting and replace the four mounting nuts.
4. Replace the air hose assembly and connect the sensor cables (B). Slide the air hose clamp (A) in place.
5. Replace the Z motor belt. Slide the motor (C) away from the Z shaft assembly and tighten the mounting screws.
6. Release the Z axis brake assembly (H) and move the Z shaft up and down slightly until the Z shaft locks.
7. Replace the roll driven belt (D) and perform the tension adjustment (4008).
8. Replace the payload if necessary.
9. Replace the Z-shaft and roll belt covers.
10. Refer to the "Axis Home Adjustment" procedure (4008) for the necessary calibration.

3323 Theta 2 Axis Motor Belt Removal

Note: Consider that Theta 2 home position will be lost.

1. Perform the "Theta 2 Axis Motor and Brush Removal" procedure (3325), steps 1 through 4.

3324 Theta 2 Axis Motor Belt Replacement

1. Perform the "Theta 2 Motor and Brush Replacement" procedure (3326), steps 5 through 7.
2. Refer to "Theta 2 Drive Belt" procedure (4014).
3. Refer to the "Axis Home Adjustment" procedure (4008) for the necessary calibration.

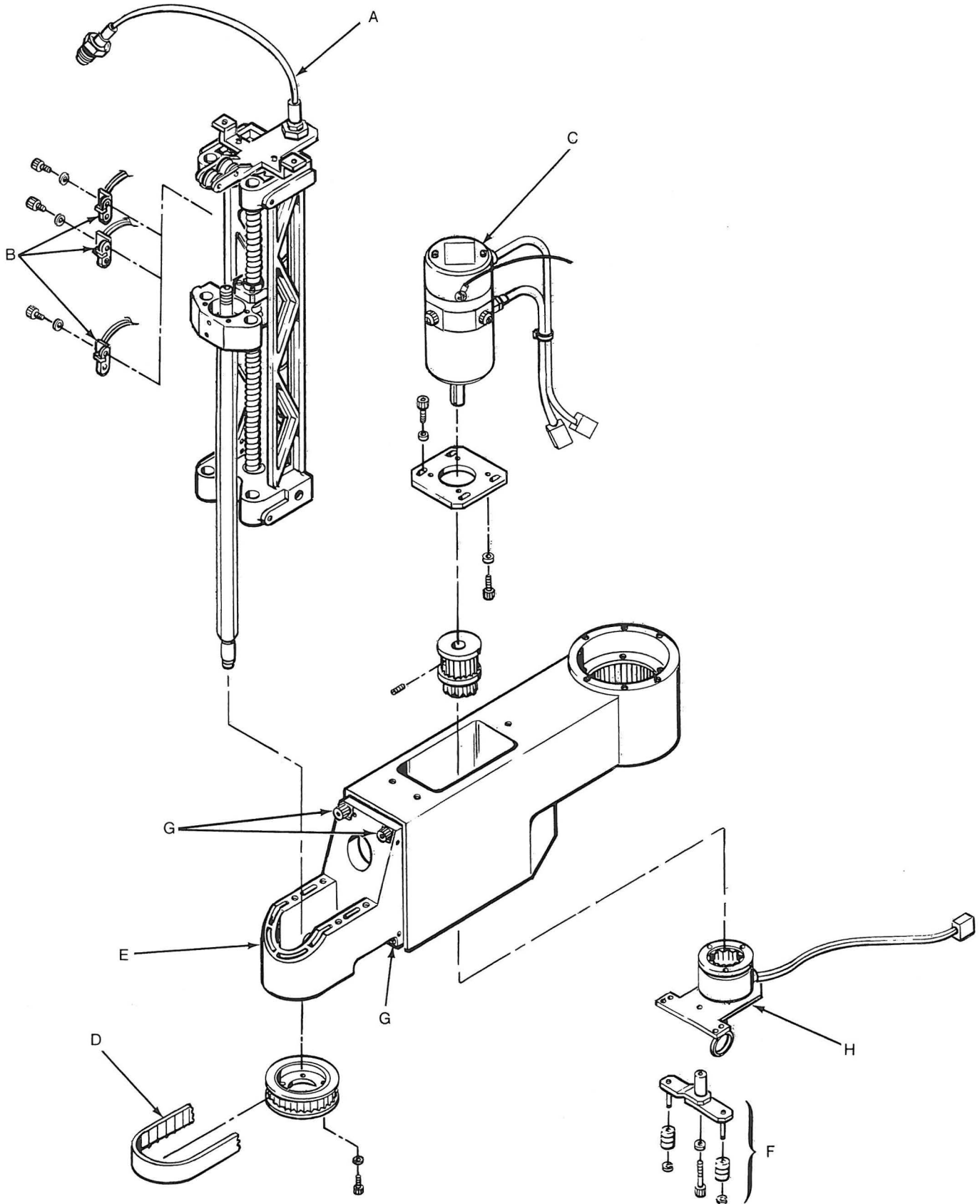

3325 Theta 2 Axis Motor and Brush Removal

Note: Consider that Theta 2 home position will be lost.

Note: If removing and replacing motor brushes only, perform steps 1 through 6.

1. Ensure that power has been turned off and removed from all units.
2. Remove the Theta 2 covers.
3. Remove the belt guard/cable bracket assembly (A) and lay aside.
4. Loosen the Theta 2 motor bracket screws (B) and slide the motor (G) toward the harmonic drive to disengage and remove the belt (E).
5. While holding the Theta 2 motor (G) from underneath the casting (K), remove the screws (B) previously loosened and lift the Theta 2 motor (G) up and out.
6. The Theta 2 motor brushes (H) can now be removed and replaced.
7. Disconnect the two motor cables (J).
8. Loosen the set screws and remove the motor pulley (D), motor mounting screws (C), and Theta 2 motor bracket (F), if necessary.

3326 Theta 2 Axis Motor and Brush Replacement

Note: If only the brushes were replaced, perform steps 4 through 8.

1. Attach the new Theta 2 motor (G) to the Theta 2 motor bracket (F) with the motor mounting screws (C).
2. Replace the Theta 2 motor pulley (D) flush with the end of the motor shaft (G).
3. Connect the two Theta 2 motor cables (J).
4. Place the Theta 2 motor (G) into the casting (K) and loosely install the Theta 2 motor bracket screws (B).
5. Install the belt (E) and slide the motor (G) away from the harmonic drive to engage the belt snugly. Tighten the motor bracket screws (B). Ensure the belt (E) tracks properly. Refer to the "Theta 2 Drive Belt" procedure (4014).
6. Replace the belt guard/cable bracket assembly (A).
7. Replace the Theta 2 covers.
8. Refer to the "Axis Home Adjustment" procedures (4008) for the necessary calibration.

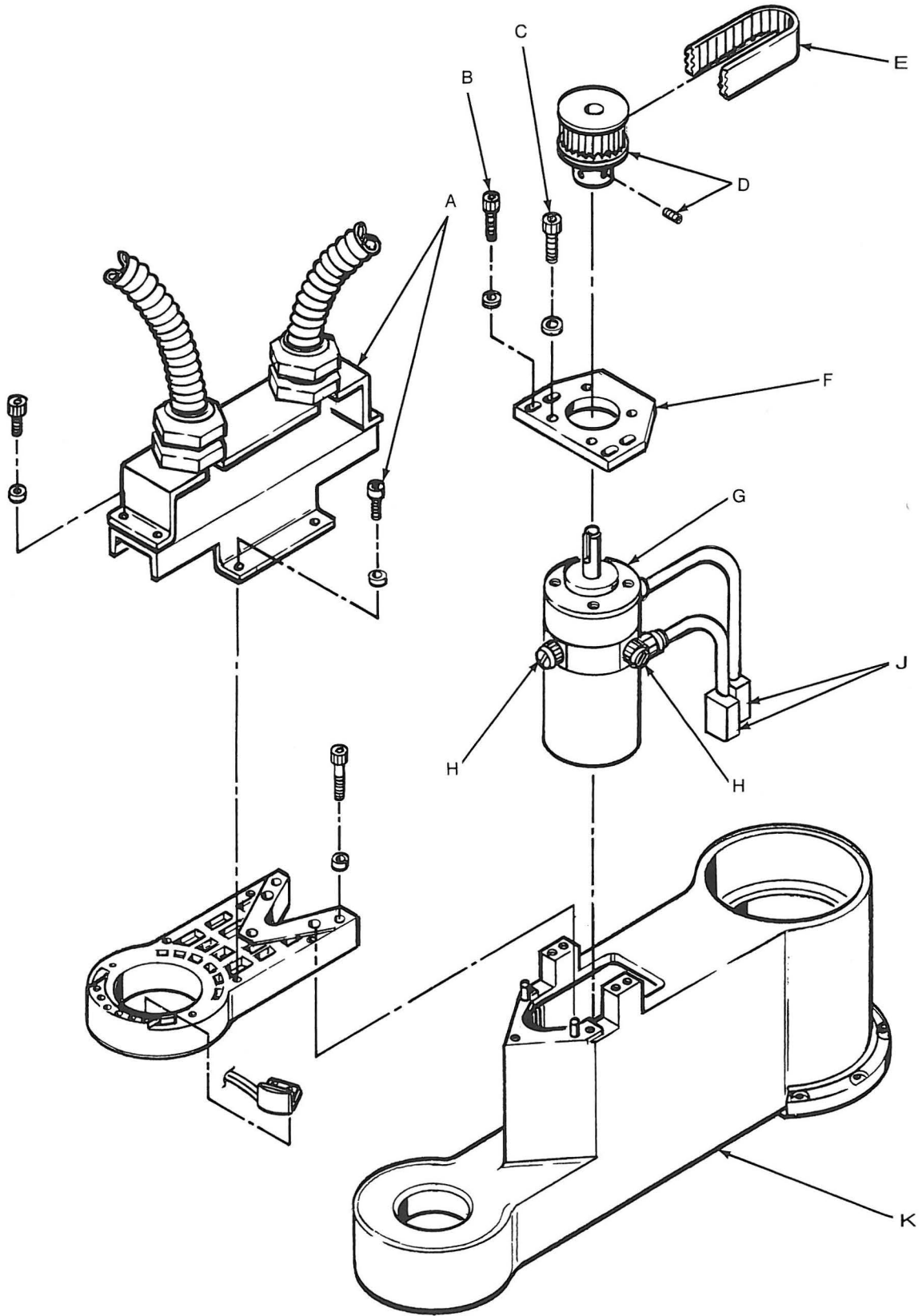

3327 Theta 2 Axis Harmonic Drive Removal

CAUTION

Two people are required to perform this task.

Note: Consider that Theta 2 home, roll home, and payload position will be lost.

Note: If a new harmonic drive is to be installed, refer to Chapter 7, "Preventive Maintenance," for proper lubrication.

1. Ensure that power has been turned off and removed from all units.
2. Remove Theta 2 and roll belt covers, and payload, if necessary.
3. Remove Theta 2 cable bracket assembly (A), and disconnect the three Theta 2 sensor cables (M); lay cable bracket assembly (A) aside.
4. Loosen the Theta 2 motor bracket screws (B) and slide the motor (G) toward the harmonic drive to remove the belt (E).

CAUTION

Do not damage the sensor home/overrun flag (L) underneath the harmonic drive pulley (DD) while performing the next step.

5. Remove the roll pin from the the Theta 2 harmonic drive pulley (DD). Remove the pulley. Bearing pullers may be required.
6. Loosen the six screws holding the three sensors. Remove three of the screws; then slide the sensors away from the home/overrun flag.
7. Loosen the two sensor home/overrun flag set screws (L), being careful not to damage the sensors (M) while lifting the sensor home/overrun flag (L) upward.
8. Remove the Theta 2 upper bearing support (K). Light tapping may be required.
9. Remove the six wave generator assembly screws (CC). Using the shaft, lift and remove the wave generator assembly (BB) from the harmonic drive (AA).
10. Loosen the roll drive and roll driven belt tensioner arms (P).
11. Remove the roll driven belt (U) by walking it off downward. Remove the roll driven pulley (T2) and flange (T1).
12. Remove the roll drive belt (S) by walking it off downward.
13. Remove the pressure clip (V) from the bottom of the Theta 2 shaft. Remove the roll drive pulley assembly (N) (contains two bearings (R) and one spacer). **Note:** A bearing puller may be needed to remove the pulley assembly.

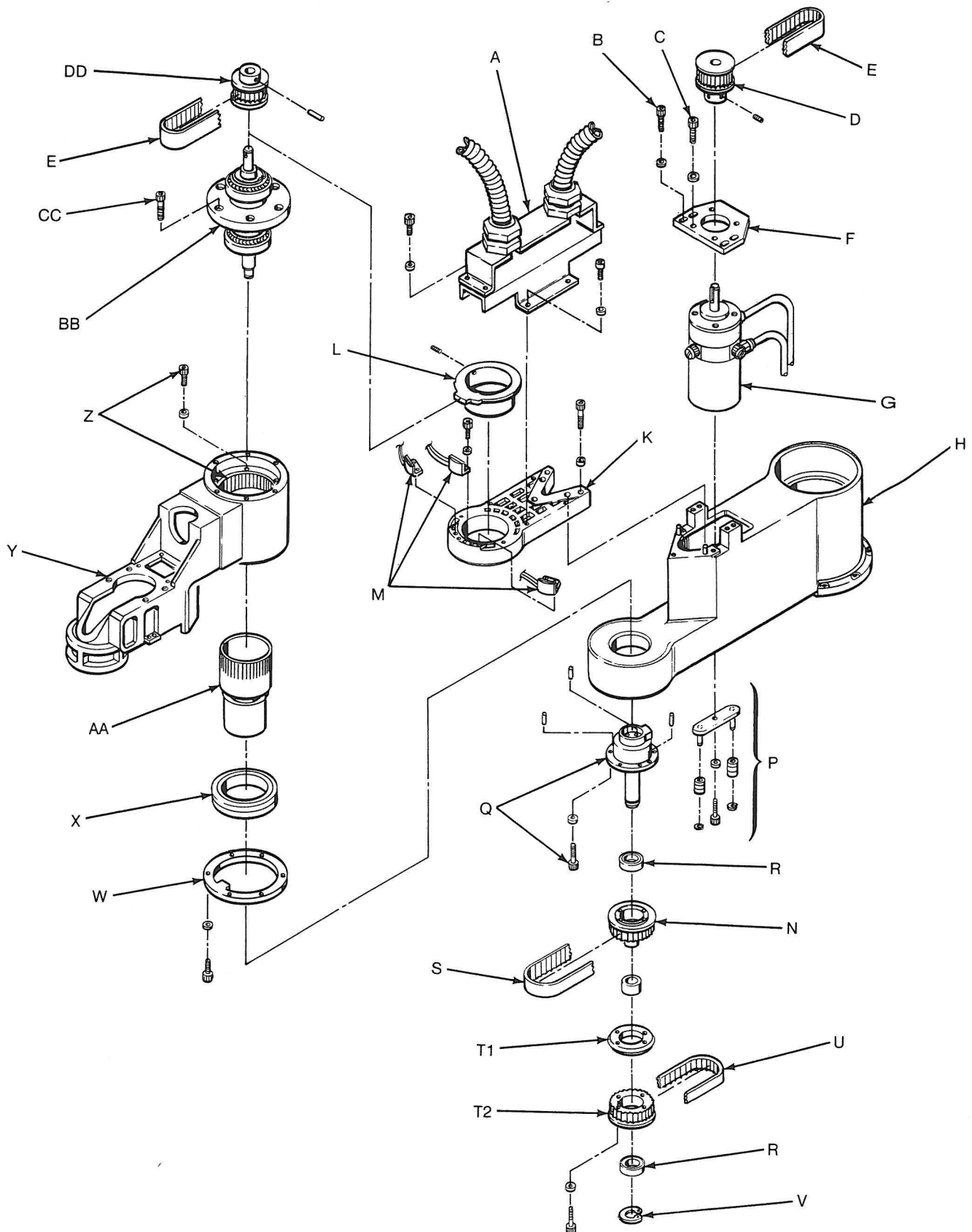

14. Remove all ten screws (Q) on the lower harmonic drive shaft retainer plate (Q). Note the position of the harmonic drive shaft retainer plate.
15. While supporting the Z-head/Theta 2 casting assembly (Y), tap downward through the small hole in the center of the harmonic drive shaft and remove the Z-head/Theta 2 casting assembly. Lay the Z-head/Theta 2 casting assembly (Y) aside.
16. Slide the flexspline out through the top of the Theta 2 casting assembly (Y).
17. The six screws holding the circular spline (Z) can now be removed.
18. Remove the circular spline.

3328 Theta 2 Axis Harmonic Drive Replacement

CAUTION

Two people are required to perform this task.

Note: The harmonic flexspline shaft, the circular spline, and the wave generator subassemblies are a matched set. If replacing any subassembly, replace the circular spline subassembly first.

Note: Ensure that all parts are well lubricated prior to reassembly. Ensure that the teeth of the flexspline and the circular spline are well lubricated. (Refer to Chapter 7, "Preventive Maintenance.")

1. Refer to the "Theta 2 Axis Inner Bearing Replacement" procedure (3330), if necessary.
2. Install the circular spline (Z), if removed. (The mounting screws should be tightened to a torque of 50 kg-cm.)
3. Install the harmonic drive shaft retainer plate (Q) with the stop to the rear (toward the back support) using the 6 outer screws
4. Place the harmonic drive shaft in the Z-head/Theta 2 casting. Align the dowel pin holes into a relative positions with the pins on the harmonic drive shaft retainer plate.
5. Using a rod to retain alignment, place the Z-head/Theta 2 casting in place onto the Theta 1 casting. Tap the Harmonic drive shaft down into the harmonic drive shaft retainer plate. Do not tap on the flexspline. Start the four inner screws to maintain alignment.
6. Tighten the four inner screws to hold the harmonic drive shaft to the retainer plate.
7. Replace the wave generator assembly (BB) and six bolts.
8. Replace the Theta 2 upper bearing support (K). Light tapping may be required.
9. Replace sensor home/overrun flag (L). With Theta 2 arm extended straight, position the sensor home/overrun flag to the rear with equal amounts of the flag on each side of the centerline of the arm.
10. Replace the sensors. Ensure that the sensor home/overrun flag (L) does not interfere with any sensor (M).
11. Replace upper harmonic drive pulley (DD) and belt (E).
12. Slide the Theta 2 motor (G) away from the harmonic drive and tighten the motor bracket screws (B). Ensure that the belt tracks properly.
13. Replace the roll drive pulley bearing (R) and the roll drive pulley (N).

14. Slide the spacer into position and replace the second bearing (R).
15. Install the snap ring (V).
16. Replace the roll drive belt (S).
17. Install the pulley flange (T1) and the roll driven pulley (T2) with the four screws.
18. Replace the roll driven belt (U).
19. Attach the sensor cable connectors (M) and replace the cable bracket assembly (A).
20. Perform the "Roll Drive Belt" and "Roll Driven Belt" procedures (4015 and 4016).
21. Replace the Theta 2 and roll belt covers, and payload if necessary.
22. Refer to the "Axis Home Adjustment" procedure (4008) for the necessary calibration.

3328 Theta 2 Axis Harmonic Drive Replacement

CAUTION

Two people are required to perform this task.

Note: The harmonic flexspline shaft, the circular spline, and the wave generator subassemblies are a matched set. If replacing any subassembly, replace the circular spline subassembly first.

Note: Ensure that all parts are well lubricated prior to reassembly. Ensure that the teeth of the flexspline and the circular spline are well lubricated. (Refer to Chapter 7, "Preventive Maintenance.")

1. Refer to the "Theta 2 Axis Inner Bearing Replacement" procedure (3330), if necessary.
2. Install the circular spline (Z), if removed.
3. Install the harmonic drive shaft retainer plate (Q) with the stop to the rear (toward the back support) using the 6 outer screws
4. Place the harmonic drive shaft in the Z-head/Theta 2 casting. Align the dowel pin holes into a relative positions with the pins on the harmonic drive shaft retainer plate.
5. Using a rod to retain alignment, place the Z-head/Theta 2 casting in place onto the Theta 1 casting. Tap the Harmonic drive shaft down into the harmonic drive shaft retainer plate. Do not tap on the flexspline. Start the four inner screws to maintain alignment.
6. Tighten the four inner screws to hold the harmonic drive shaft to the retainer plate.
7. Replace the wave generator assembly (BB) and six bolts.
8. Replace the Theta 2 upper bearing support (K). Light tapping may be required.
9. Replace sensor home/overrun flag (L). With Theta 2 arm extended straight, position the sensor home/overrun flag to the rear with equal amounts of the flag on each side of the centerline of the arm.
10. Replace the sensors. Ensure that the sensor home/overrun flag (L) does not interfere with any sensor (M).
11. Replace upper harmonic drive pulley (DD) and belt (E).
12. Slide the Theta 2 motor (G) away from the harmonic drive and tighten the motor bracket screws (B). Ensure that the belt tracks properly.
13. Replace the roll drive pulley bearing (R) and the roll drive pulley (N).

14. Slide the spacer into position and replace the second bearing (R).
15. Install the snap ring (V).
16. Replace the roll drive belt (S).
17. Install the pulley flange (T1) and the roll driven pulley (T2) with the four screws.
18. Replace the roll driven belt (U).
19. Attach the sensor cable connectors (M) and replace the cable bracket assembly (A).
20. Perform the "Roll Drive Belt" and "Roll Driven Belt" procedures (4015 and 4016).
21. Replace the Theta 2 and roll belt covers, and payload if necessary.
22. Refer to the "Axis Home Adjustment" procedure (4008) for the necessary calibration.

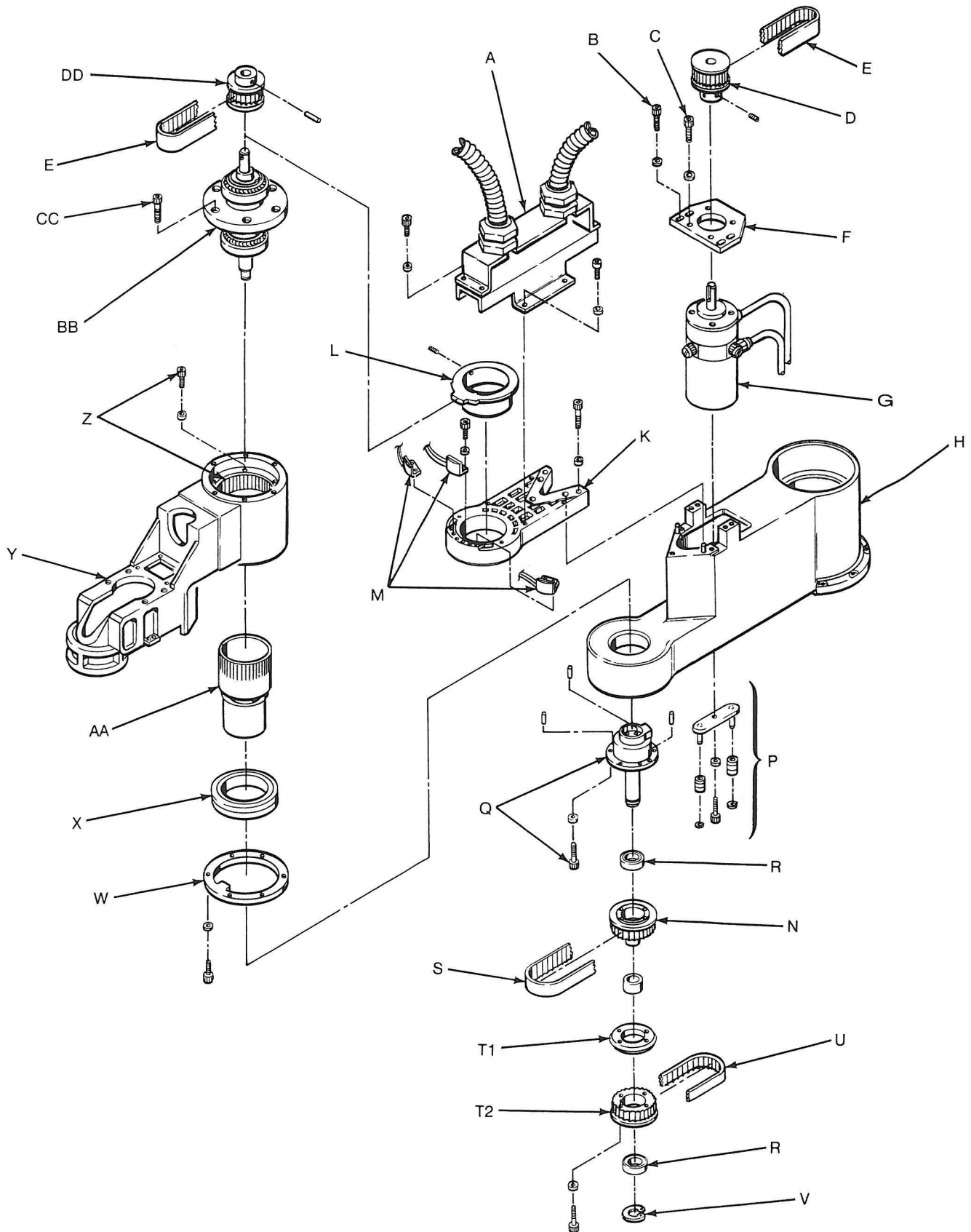

3329 Theta 2 Axis Inner Bearing Removal

Note: Consider that Z home and payload position will be lost.

1. Perform the "Theta 2 Axis Harmonic Drive Removal" procedure (3327).
2. Remove the six screws on the inner bearing retainer plate (W), noting the location of the final stop.
3. Slide the inner bearing (X) out of the Theta 2 casting (Y).

3330 Theta 2 Axis Inner Bearing Replacement

1. Press the inner bearing (X) into the Theta 2 casting (Y).
2. Install the inner bearing retaining plate (W). The final stop on the plate should be positioned towards the Z axis.
3. Perform the "Theta 2 Axis Harmonic Drive Replacement" procedure (3328).

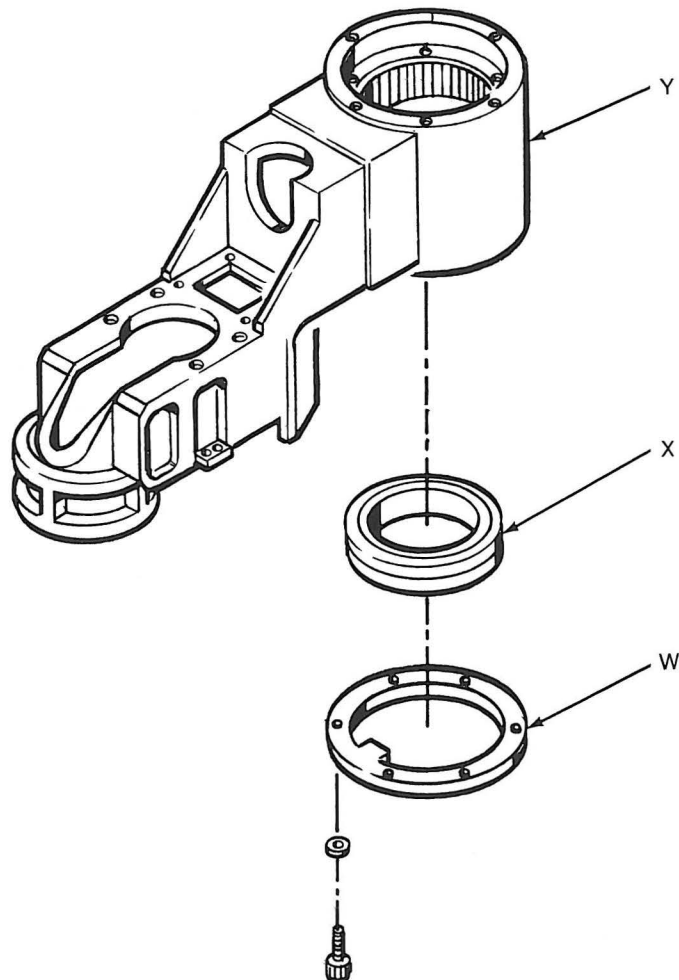

3331 Theta 1 Axis Motor Brush

1. Remove the Theta 1 motor cover(s). Refer to the "Cover Removals and Replacements" (3301).
2. Access holes (B) have been provided for Theta 1 motor brush (A) removal and replacement.
3. Replace the Theta 1 motor covers when completed.

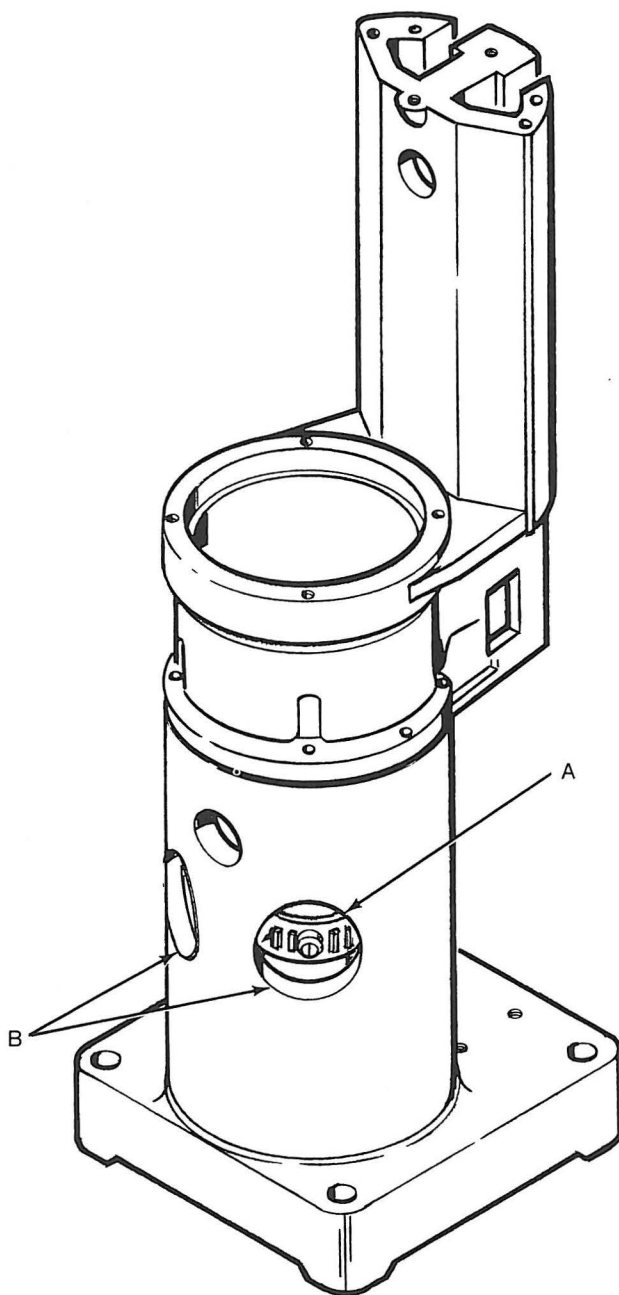

3332 Theta 1 Axis Harmonic Drive Removal

CAUTION

Three people may be required to perform this task; this procedure removes the manipulator from the base.

Note: Consider that Theta 1 home, roll home, and payload position will be lost.

Note: If a new harmonic drive is to be installed, refer to Chapter 7, "Preventive Maintenance," for proper lubrication.

1. Ensure that power has been turned off and removed from all units.
2. Remove all covers from the base, the back support, and both arms.
3. Perform the "Roll Axis Driven and Drive Belt Removal" procedure (3340).
4. Disconnect the two Theta 1 motor (U) cables and the motor ground strap from the main cable connector bracket and feed through the opening in the base.
5. Remove the roll sensor bracket.
6. Disconnect the two roll motor cables and motor ground.
7. Remove the four screws holding the main cable connector assembly bracket (W), remove the bracket and pull the wiring out of the back support (M).

Warning: Support the arm assembly prior to removing the bolts from the Theta 1 top support and the Theta 1 casting.

Note: The bolts removed in the following step can be used in step 12.

8. Remove the four Theta 1 top support bolts (L) and remove the Theta 1 top support. Light tapping is required.
9. Remove the five upper harmonic drive plate bolts (A) from the Theta 1 casting (B).

CAUTION

Three people are required to lift the arm assembly.

10. Lift the arm assembly (B) from the back support (M) and remove.
11. Remove the four upper harmonic drive plate bolts (C).

Note: Place a metal shim of 5/8 inch thickness, or equivalent, between the end of each bolt and the harmonic drive flange to protect the harmonic drive flange.

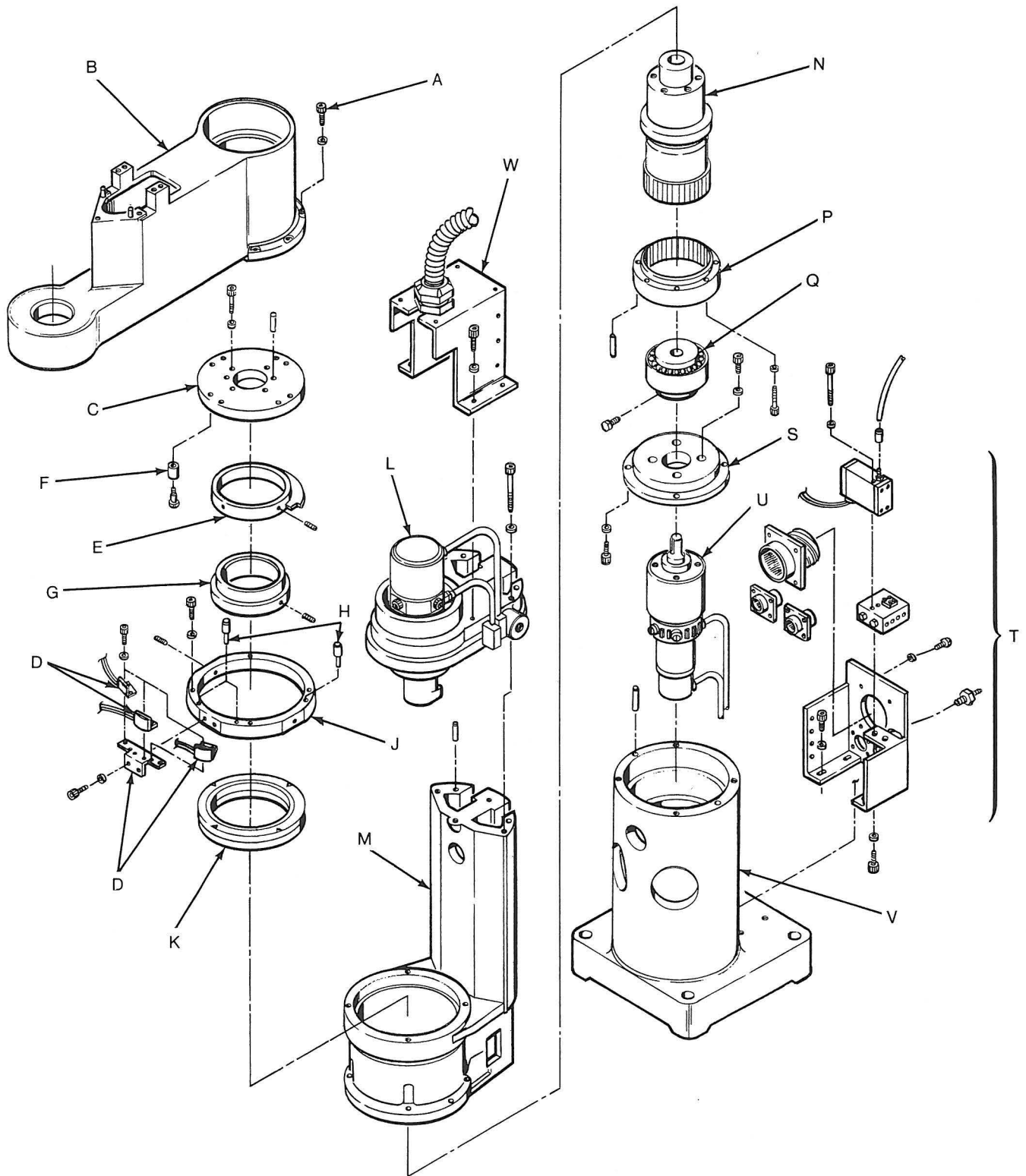

12. Insert three bolts through the upper harmonic drive plate (C).
13. Pull the upper harmonic drive plate (C) from the harmonic drive (N) by tightening equally the three bolts.
14. Remove the Theta 1 sensor assembly (D).
15. Loosen the two set screws on the home/overrun flag (E).

Note: Mark the home/overrun flag with reference to the harmonic drive assembly and the back support.

Note: Each set screw has a brass insert to protect the harmonic drive's threads. Do not lose the brass inserts when removing the home/overrun flag.

16. Remove the home/overrun flag (E) from the harmonic drive (N).
17. Remove the four inner bearing flange plate screws and remove the inner bearing flange plate (J).
18. Slide the harmonic drive retaining collar (G) straight up and remove the collar.
19. Remove the four back support bolts (M) from the base (V).

CAUTION

Two persons are required to lift the back support from the base.

20. Lift the back support (M) from the base (V).
21. Remove the six Theta 1 motor flange bolts (S).
22. Remove the Theta 1 motor (U) and wave generator (Q) from the back support (M).
23. Slide the flexspline (N) and lower inner bearing (K) out through the bottom of the back support.

Note: Each set screw has a brass insert to protect the harmonic drive's threads. Do not lose the brass inserts when removing the lock nut.

24. Remove the six bolts from the circular spline (P) on the bottom of the back support.
25. Remove the three circular spline pins (R) and then, pull the circular spline out.
26. Remove the wave generator assembly (Q).

3333 Theta 1 Axis Harmonic Drive Replacement

Note: The harmonic flexspline shaft, circular spline, and wave generator subassemblies are a matched set. If replacing any subassembly, replace the circular spline subassembly first.

Note: Ensure that all parts are well lubricated prior to reassembly. Ensure that the teeth of the flexspline and the circular spline are well lubricated. (Refer to Chapter 7, "Preventive Maintenance.")

1. Install the circular spline (P) using the three spline pins (R) and the six bolts. (The mounting screws should be tightened to a torque of 50 kg-cm.)
2. Slide the lower inner bearing (K) onto the flexspline (N).
3. Install the flexspine (N) and lower inner bearing (K) up through the bottom of the back support.
4. Install the inner bearing flange plate(J).
5. Install the wave generator assembly onto the Theta 1 motor (2 mm clearance between the motor flange and the base assembly).
6. Install the Theta 1 motor (U) and wave generator assembly (Q) (The motor wires should be approximately 45 degrees to the right of the back support (M)).
7. Install the back support (M) to the base (V) (Slide motor wires down through and out the side of the base (V) while installing the back support to the base).
8. Install the collar (G).
9. With the flag side down, install the home/overrun flag (E) only snugly, so adjustment can be made later.
10. Install the Theta 1 sensor assembly (D).

Note: Ensure that the stop pin on the upper harmonic drive plate is not between the two stop pins on inner bearing flange. This location is where the sensors will be placed and would not provide sufficient Theta 1 travel.

11. Install the upper harmonic drive plate (C).
12. Install the arm assembly.

Note: Install the roll drive belt prior to pushing the top support down.

13. Install the Theta 1 top support.

14. Connect the Theta 1 motor cables and ground wire.
15. Install the main cable connector assembly bracket (W).
16. Connect the Roll axis motor cables and ground wire.

Note: Rotate the Roll axis until the low portion of the flag is shown.

17. Install the Roll sensor bracket assembly.
18. Perform the "Roll Axis Driven and Drive Belt Replacement" procedure (3341).
19. Perform the "Axis Home Adjustment" procedure (4008).
20. Replace all removed covers.

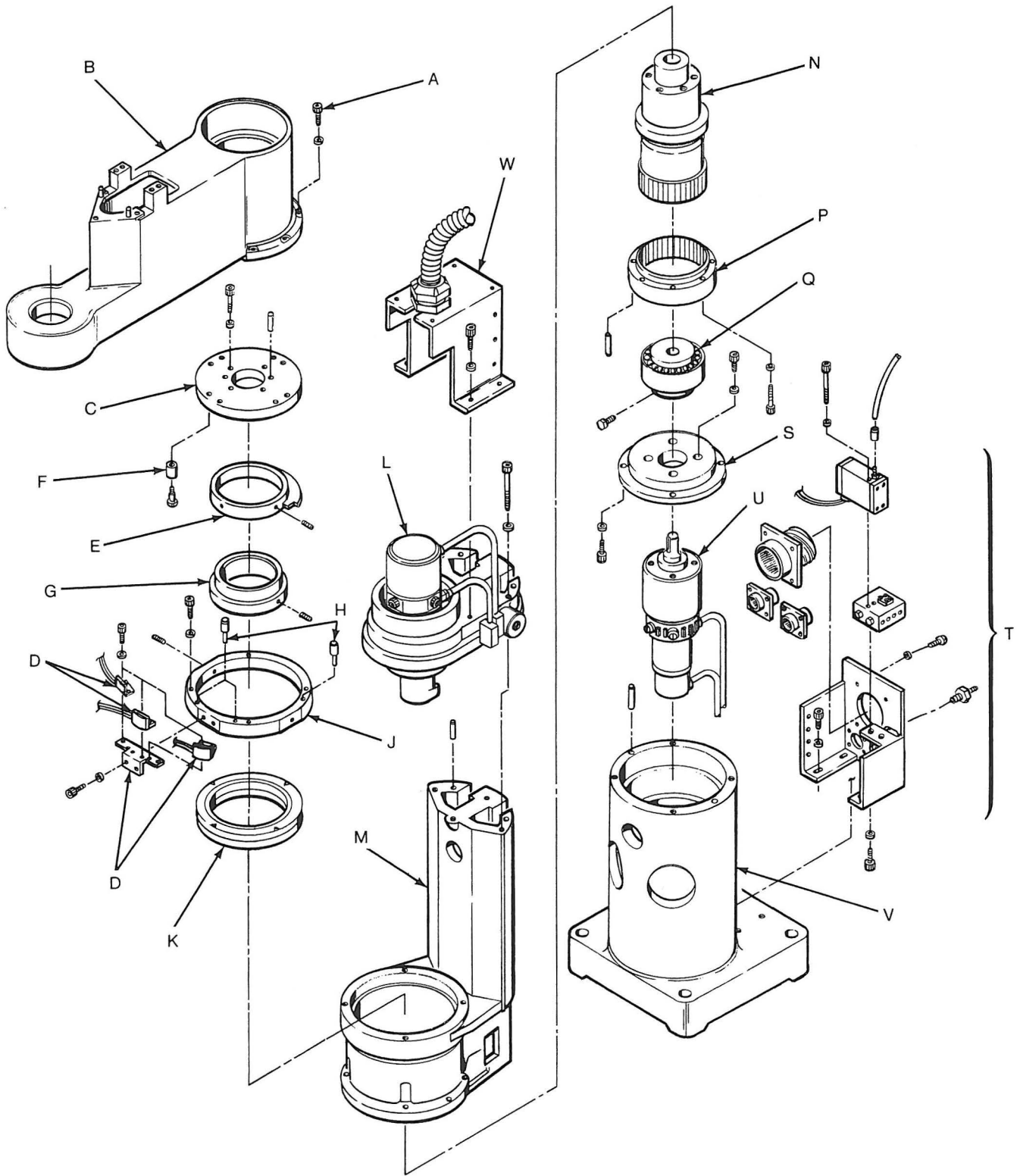

3334 Theta 1 Axis Motor Removal Procedure

Note: Consider that Theta 1 home position will be lost.

1. Perform the "Theta 1 Axis Harmonic Drive Removal" procedure (3332), steps 1 through 4.
2. Remove the Theta 1 sensor bracket assembly (F) and lay the sensor assembly and cable aside.
3. Install the two eyebolts (A) in the back support (D).
4. Connect a lifting sling to the eyebolts (A).
5. Remove the four back support (D) bolts from the base (K).
6. Fold the Theta 2 casting into the Theta 1 casting as a left arm.
7. Use a fork lift or portable crane to lift the manipulator assembly (C) from the base (K).
8. Lay the manipulator (C) on its left side on the work space.
9. Remove the six Theta 1 motor flange (H) bolts and washers.
10. Remove the Theta 1 motor (J) and wave generator (G) assembly.
11. Remove the wave generator (G) assembly from the Theta 1 motor (J).

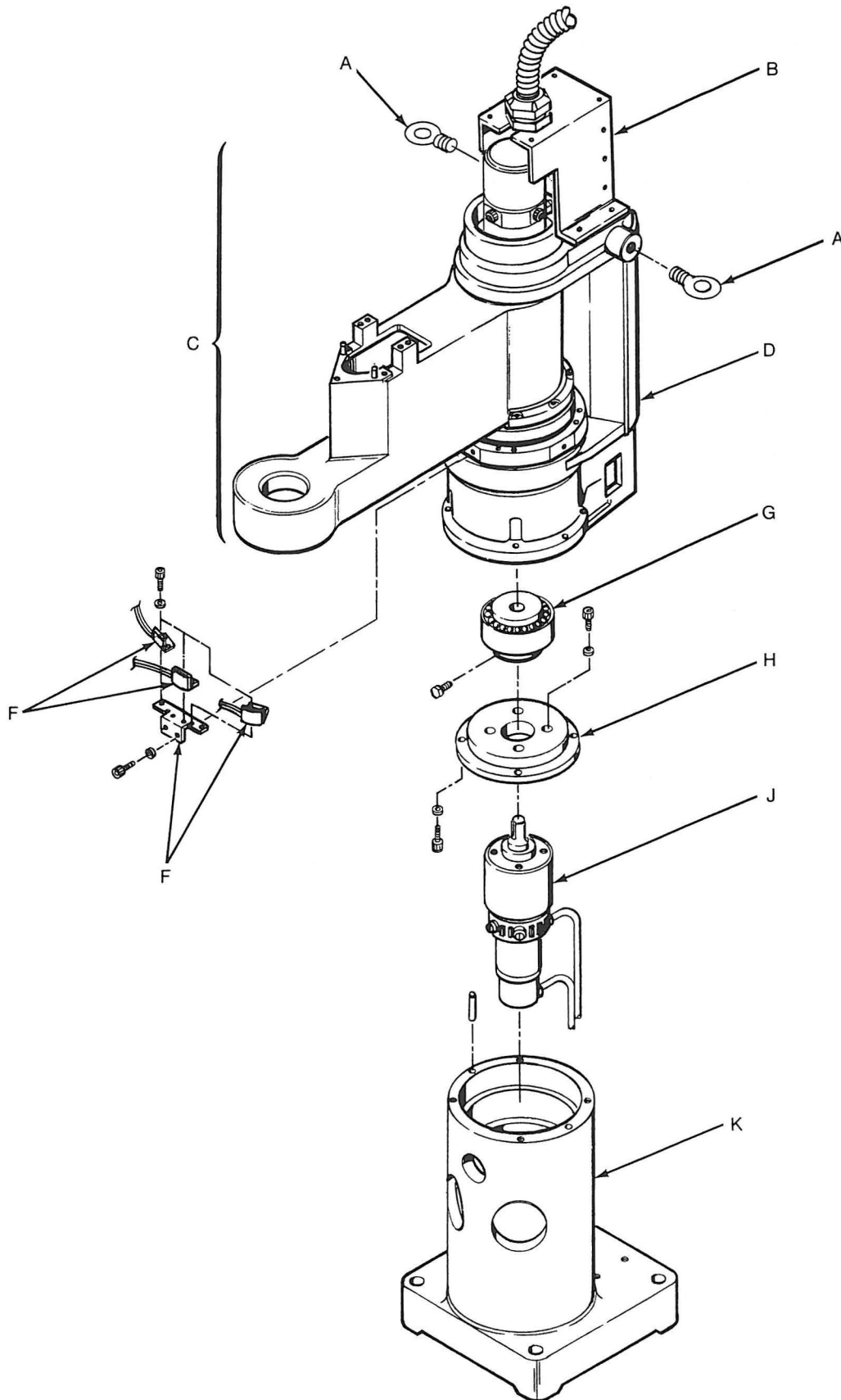

3335 Theta 1 Axis Motor Replacement

Note: Ensure that all parts are well lubricated prior to reassembly. Ensure that the teeth of the flexspline and the circular spline are well lubricated.

1. Install the wave generator assembly (G) onto the Theta 1 motor (J) (2 mm clearance between the motor flange and wave generator assembly base) .
2. Install the Theta 1 motor (J) and wave generator (G) assembly with the six Theta 1 motor flange (H) bolts and washers.
3. Install the two eyebolts (A) in the back support (D).
4. Connect a lifting sling to the eyebolts (A).
5. Fold the Theta 2 casting into the Theta 1 casting as a left arm.
6. Use a fork lift or portable crane to lift the manipulator assembly (C) onto the base (K).
7. Install the four base bolts (E) and tighten.
8. Remove the fork lift or portable crane.
9. Remove the sling and the eyebolts (A) from the back support (D).
10. Install the Theta 1 sensor bracket (F) and cable.
11. Install the main cable connector assembly bracket (B) and tighten the screws.
12. Install all covers on the base, the back support, and both arms.
13. Perform the "Axis Home Adjustment" procedure (4008).

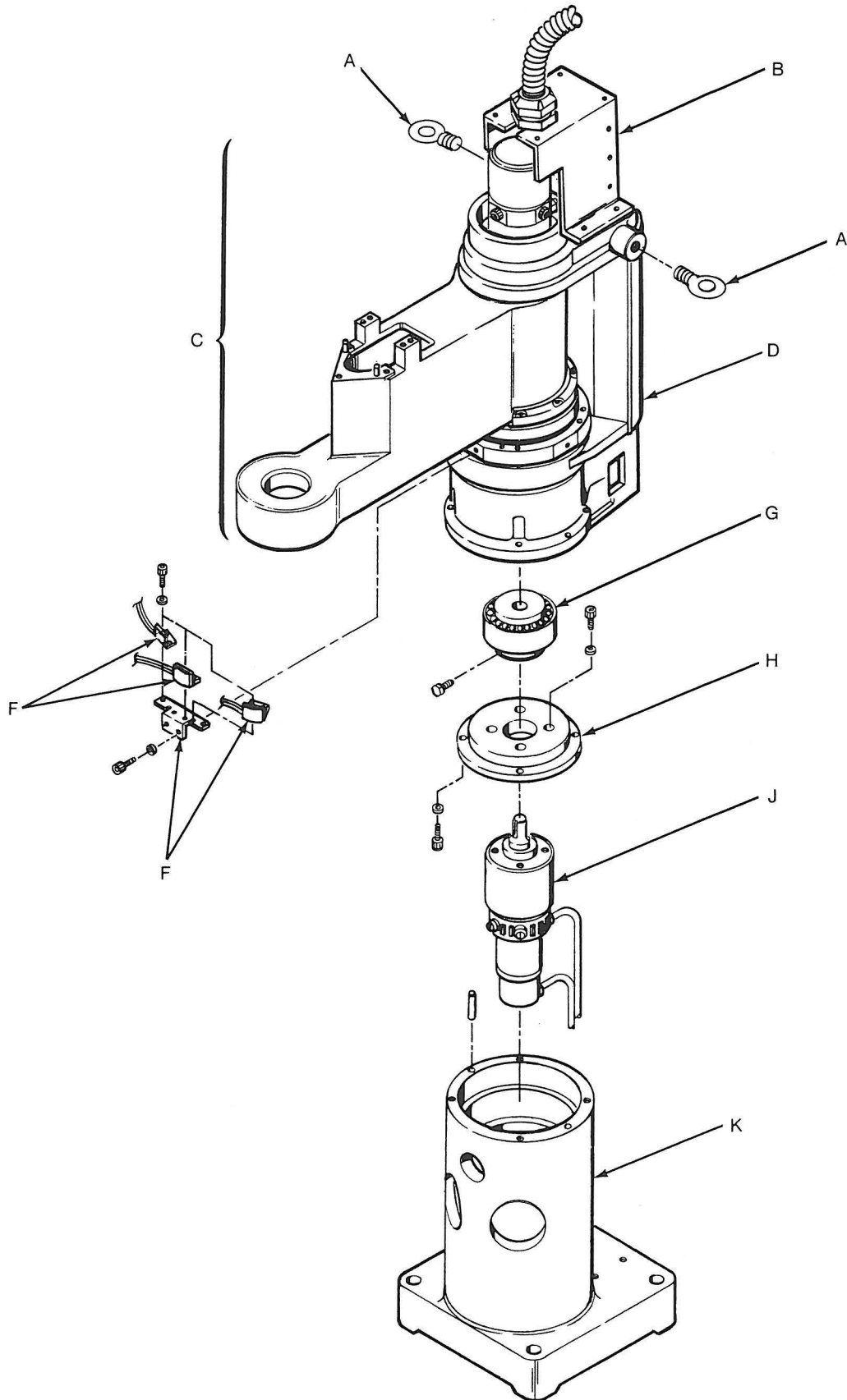

3336 Theta 1 Upper Support Bearing Removal

Note: Consider that roll home position and payload position will be lost

1. Perform the "Roll Axis Harmonic Drive Removal" procedure (3344), steps 1 through 9.
2. Remove the inner bearing (A). A bearing puller may be required.

3337 Theta 1 Upper Support Bearing Replacement

1. Install the inner bearing (A).
2. Perform the "Roll Axis Harmonic Drive Replacement" procedure (3345), steps 7 through 15.

3338 Theta 1 Lower Inner Bearing Removal

Note: Consider that theta 1 home, roll home, and payload position will be lost.

1. Perform the "Theta 1 Axis Harmonic Drive Removal" procedure (3332) to remove the Theta 1 lower inner bearing.

3339 Theta 1 Lower Inner Bearing Replacement

1. Perform the "Theta 1 Axis Harmonic Drive Replacement" procedure (3333) to replace the Theta 1 lower inner bearing.

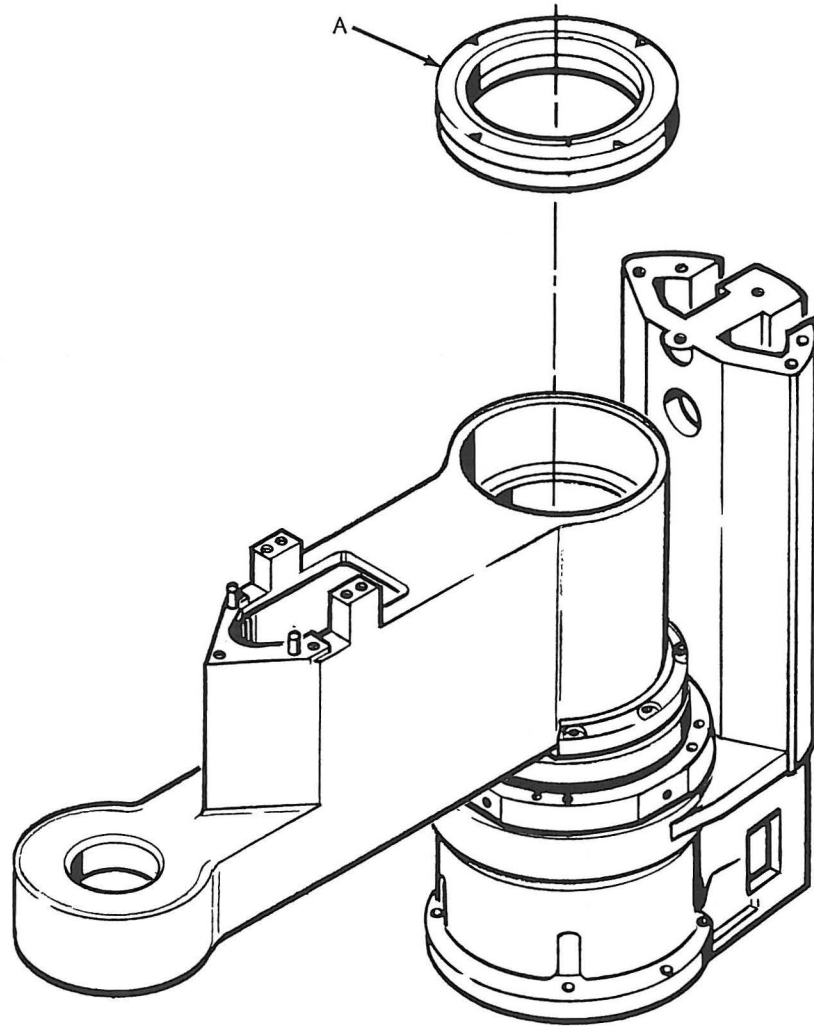

3340 Roll Axis Driven and Drive Belt Removal

Note: Consider that roll home position and payload position will be lost.

Note: For the driven belt, perform steps 1 through 6 only.

1. Ensure that power has been turned off and removed on all units.
2. Extend the arm as necessary to reach the roll belts.
3. Remove the roll belt cover.
4. Loosen the driven belt tensioner arm (A).
5. Remove the four mounting screws from the driven belt pulley (E).
6. Remove both the driven belt pulley (E) and the roll driven belt (B).
7. Loosen the drive belt tensioner arm (D).
8. Remove the roll drive belt (C).

3341 Roll Axis Driven and Drive Belt Replacement

Note: For the driven belt, perform steps 3 through 6.

1. Replace the roll drive belt (C).
2. Perform the "Roll Drive Belt" adjustment procedure (4015).
3. Replace both the roll driven pulley (E) and the roll driven belt (B).
4. Reinstall the four mounting screws on the driven belt pulley (E).
5. Perform the "Roll Driven Belt" adjustment procedure (4016).
6. Replace the roll belt cover.
7. Refer to "Axis Home Adjustment" procedure (4008) for the necessary calibration.

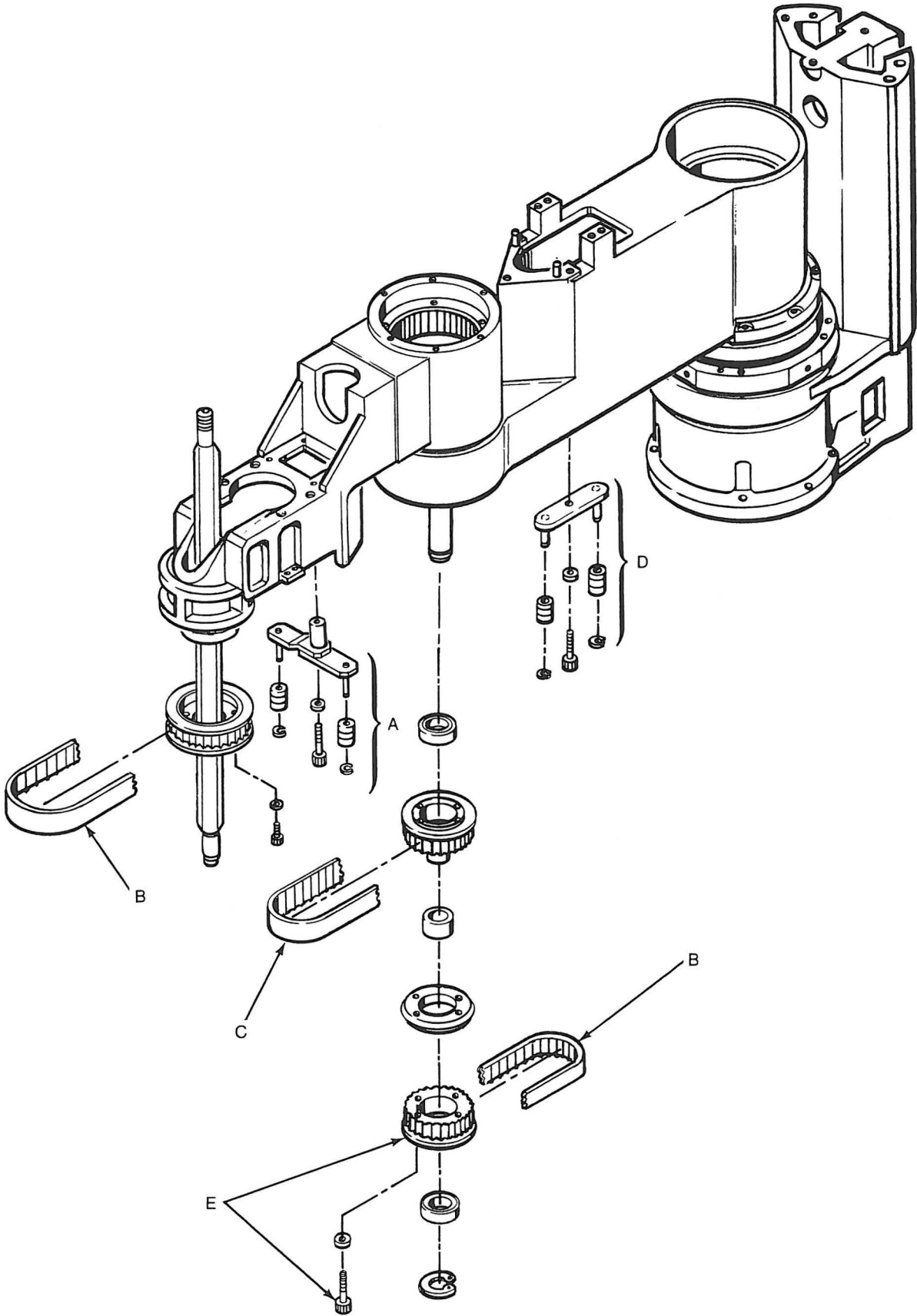

3342 Roll Axis Motor and Brush Removal

Note: Consider that roll home position and payload position will be lost.

1. Ensure that power is turned off and removed from all units.
2. Remove the roll motor covers.
3. The roll motor brushes (C) can now be removed and replaced.
4. Remove the cable bracket assembly (A) and lay aside.
5. Disconnect the two roll motor cables (B) and ground wire.
6. Remove the roll motor (D).
7. Remove the wave generator from the roll motor shaft, if necessary. Note the position of the wave generator on the motor shaft.

3343 Roll Axis Motor Replacement

Note: Ensure that the wave generator is completely lubricated.

1. If necessary, place the wave generator on the roll motor shaft.
2. Replace the roll motor (D) assembly into the harmonic drive.
3. Connect the two motor cables (B) and ground wire.
4. Replace the cable bracket assembly (A).
5. Replace the roll motor covers.
6. Refer to "Axis Home Adjustment" procedures (4008) for the necessary calibration.

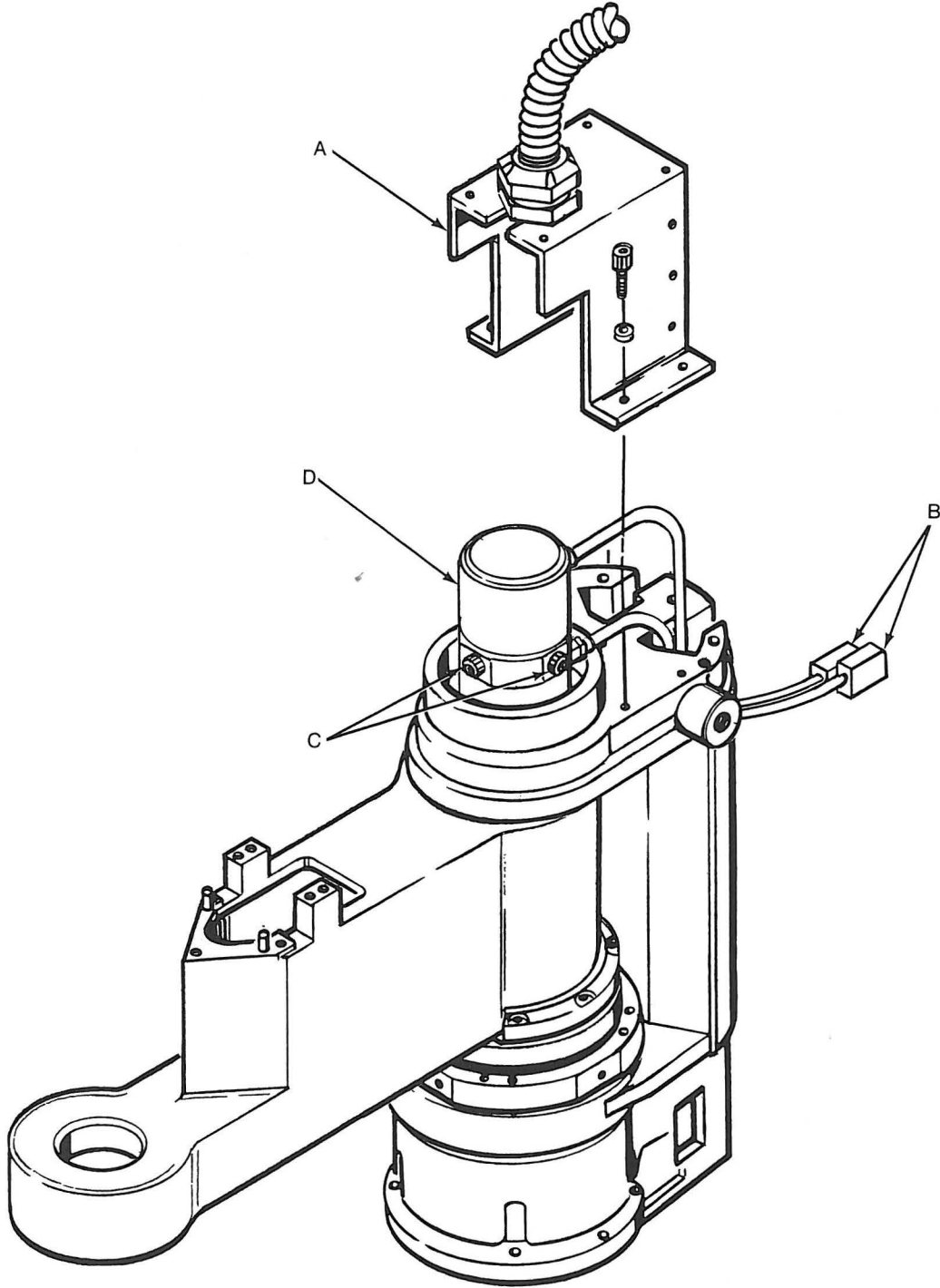

3344 Roll Axis Harmonic Drive Removal

Note: Consider that roll home position and payload position will be lost.

Note: If a new harmonic drive is to be installed, refer to Chapter 7, "Preventive Maintenance," for proper lubrication.

1. Ensure that power is turned off and removed from all units.
2. Remove the roll motor covers.
3. Remove the payload and the roll belt cover.
4. Loosen roll drive and driven belt tensioner arms (M).
5. Remove the roll driven belt.
6. Remove the roll drive belt (L) from the roll drive pulley (K).
7. Remove the cable bracket assembly (A) and lay aside.
8. Disconnect the roll motor cables, the roll sensor bracket (H), and the ground wire. (One of the bolts may be hidden under the cables.)
9. Remove the Theta 1 support (G) with the harmonic drive assembly. Four bolts hold the bracket. Light tapping may be required.
10. Loosen the two set screws holding the locknut (N) and remove the locknut (do not loose the brass inserts).
11. Remove the drive pulley assembly (K) from the harmonic drive shaft (F). Two set screws hold the pulley. Note the position of the pulley on the shaft. (A wheel or bearing puller may be needed.)

Note: The flexspline may come out with the roll motor. If it does not, lightly tap it up and out.

12. Remove the roll motor (C).
13. Remove the flexspline (F), if it did not come out with the roll motor. Light tapping may be required.

Note: The circular spline has a tight fit within the joint and may require a puller to be removed. Be careful not to damage the teeth on the inner portion of the part. Use the hole in the top of the casting for access with a brass punch or puller fingers.

14. Remove the circular spline (E).
15. Remove the wave generator (D) from the roll motor. Note the position of the wave generator on the motor shaft.

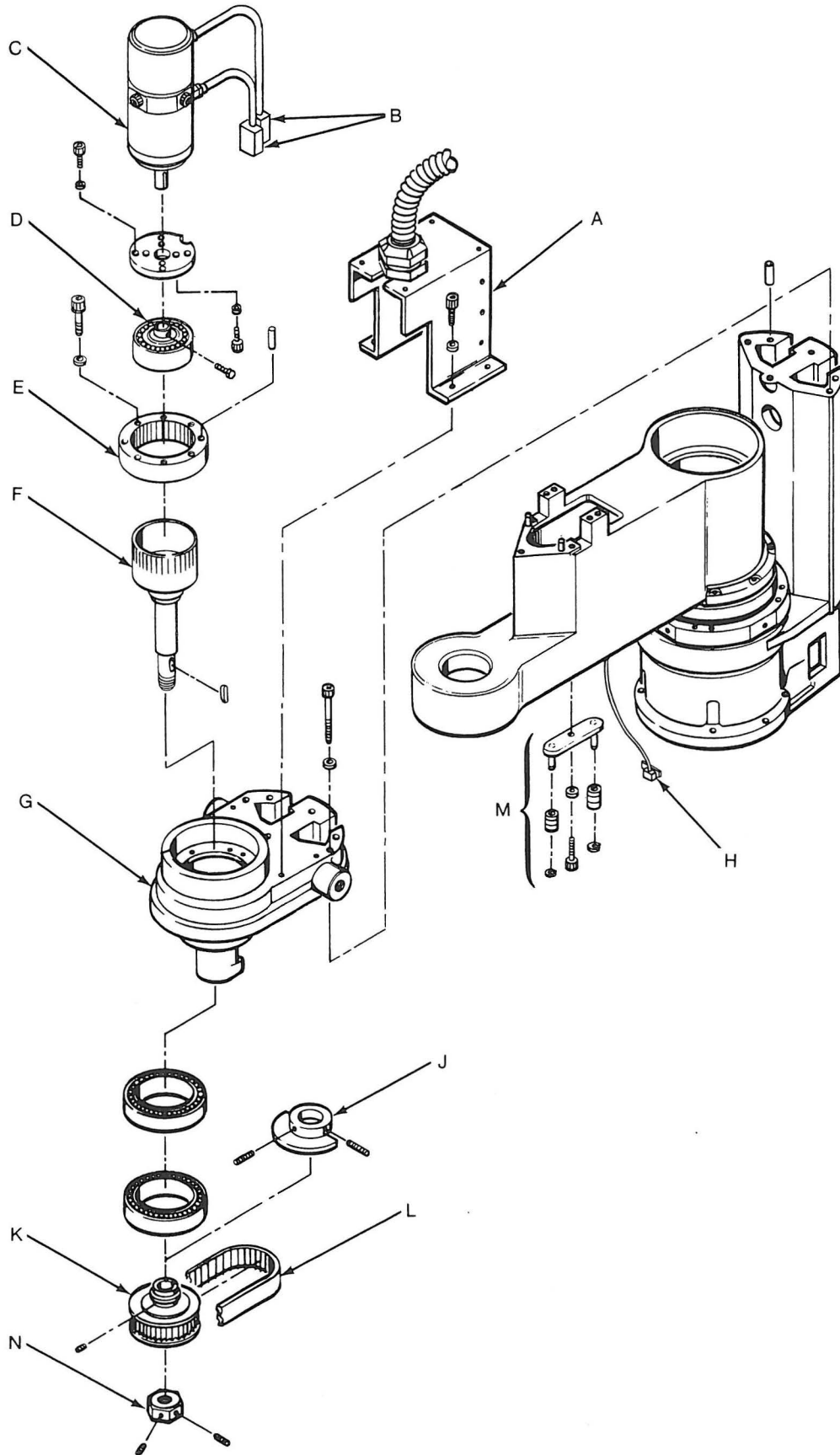

3345 Roll Axis Harmonic Drive Replacement

Note: The harmonic flexspline shaft, circular spline, and wave generator are a matched set. Ensure each piece stays with its set and that that all replacements are as a set.

Note: Ensure that all parts are well lubricated prior to reassembly. Ensure that the teeth of the flexspline and the circular spline are well lubricated. (Refer to Chapter 7, "Preventive Maintenance.")

1. Install the circular spline (E). (The mounting screws should be tightened to a torque of 30 kg-cm.)
2. Install the flexspline assembly (F).
3. Install the wave generator assembly (D) on the roll motor shaft (C), if necessary. Ensure the screws are tight.
4. Install the roll motor (C) with the wave generator (D).
5. Install the drive pulley assembly (K).
6. Install the locknut (N) with brass inserts and tighten the set screws.
7. Install the Theta 1 top support (G) with the harmonic drive assembly. Light tapping may be required.
8. Install the cable bracket assembly (A).
9. Connect the roll motor cables (B) and ground wire.
10. Install the roll drive belt (L).
11. Install the roll driven belt.
12. Perform the "Roll Drive Belt" procedure (4015) and the "Roll Driven Belt" procedure (4016).
13. Install the roll belt cover and the payload.
14. Replace the roll motor cover.
15. Refer to "Axis Home Adjustment" procedures (4008) for the necessary calibration.

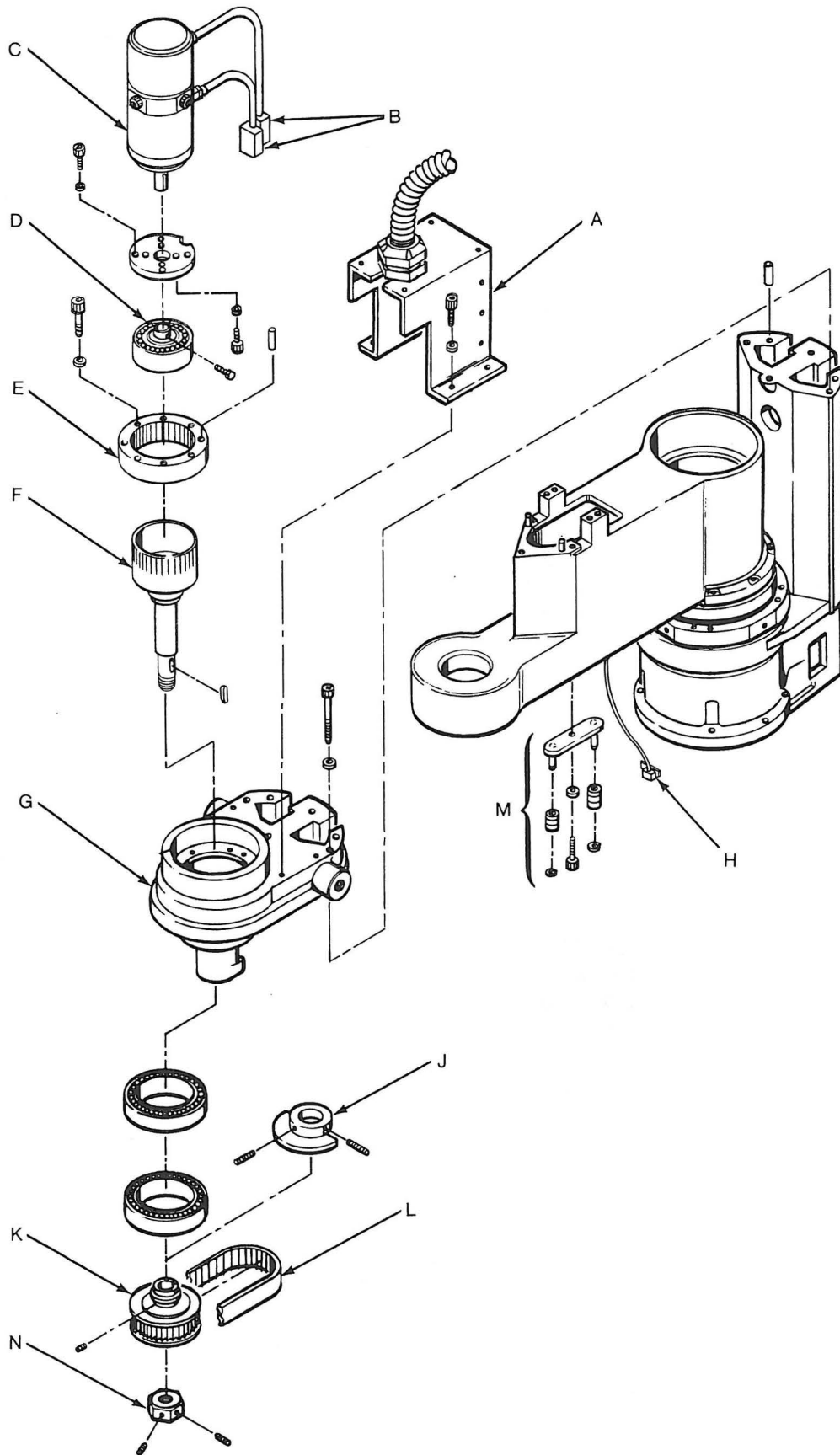

3346 Roll Upper Inner Bearing Removal

Note: Consider that roll home position and payload position will be lost.

1. Perform the "Roll Axis Harmonic Drive Removal" procedure (3344), steps 1 through 13.
2. Remove the inner bearing (A) from the harmonic drive shaft (B). A bearing puller may be required.

3347 Roll Upper Inner Bearing Replacement

1. Install the inner bearing (A).
2. Perform the "Roll Axis Harmonic Drive Replacement" procedure (3345), steps 2 through 15.

